

Arval

by ArcelorMittal



ArcelorMittal

Floor systems guide

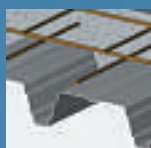

COFRASOL



COFRAPLUS



COFRASTRA



COFRASTRA DÉCIBEL

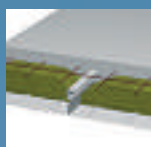

COFRADAL 200

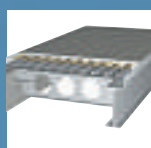

GLOBALFLOOR

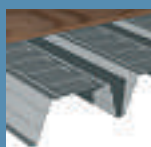

SUPPORTSOL



SUPPORTSOL DÉCIBEL



COFRATHERM



transforming
tomorrow

Arval floor[®] system offer

Families	Designation	Systems	
Floors on self-supporting formwork	COFRASOL [®]	Cofrasol 39 Cofrasol 40 Cofrasol 60 Cofrasol 118	
Composite floors Composite floors with open-ribs	COFRAPLUS [®]	Cofraplus 60 Cofraplus 77	
Composite floors with high bonding capacity	COFRASTRA [®]	Cofrastra 40 Cofrastra 70	
Multifunction composite floors	COFRASTRA DÉCIBEL [®]	Cofrastra Décibel 40 Cofrastra Décibel 70	
Prefabricated floor *	COFRADAL [®]	Cofradal 200	
	COFRADAL DÉCIBEL [®]	Cofradal 200 Décibel	
Dry floors	SUPPORTSOL [®]	Supportsol 40 Supportsol 56 Supportsol 74 Supportsol 118 Supportsol 170	
	COFRATHERM [®]	Cofratherm*	
	SUPPORTSOL DÉCIBEL [®]	Supportsol Décibel	

Arval[®] flooring systems are covered by patents and registered trademarks.

* Arval[®] flooring systems not available in South Africa.

introduction

Arval presents to you its range of floor construction systems. This range is the most comprehensive on the market and consists of both well established systems and innovative solutions which reflect recent developments in regulation, design and installation.

Arval has drawn on more than 30 years of experience in the completion of thousands of international projects in all types of buildings – both new-build and renovation. Most importantly, in every country Arval is by your side from the project design and engineering stage to the execution stage with professional teams who analyse your project, propose the best solutions for your requirements, and provide you with continuous technical assistance both for design calculations and layout drawings, right through to the initial building work.

table of contents

BUILDING

The key benefits of Arval floors systems.....	6
Formwork function and speed of implementation.....	6
A finished and sealed underside.....	6
A floor bringing safety to the work site	7
Overall savings	7
Fire behaviour	7
Arval floor systems offer.....	8
Floors on self-supporting formwork	
Cofrasol	9
Composite floors	10
Cofraplus	11
Cofrastra	12
Cofrastra Décibel	13
Prefabricated floors	14
Cofradal 200	14
Cofradal 200 Décibel	15
Dry floors	16
Supportsol	16
Supportsol Décibel	17
Cofratherm	17
The decisive advantages of Arval floor system	18
Reference projects	20
Renovation	21
Elevated car parks	22
Underground car parks.....	24
Office buildings	26
Activity buildings and shopping centres	28
Collective and individual housing	30
Non-residential buildings: health, schools, infrastructures.....	31
Sustainable development	32
How to choose the most suitable system?.....	34

DESIGNING

Arval floor system frames	38
Performance of Arval composite floor systems	39
Compliance of Arval floor systems with regulations	42
Design criteria	44
Floor thickness	44
Deflection.....	45
Natural frequency	45
Reinforcement.....	46
Support structures	48
Laying methods.....	49
Steel girdering.....	50
Steel girdering.....	52
Floor openings.....	53
Fire behaviour	54
Acoustic behaviour.....	56
Thermal insulation	58
Use in seismic areas	60
Design examples	61

CALCULATING

Cofra software	66
GlobalFloor software.....	68

IMPLEMENTING

Implementation sequences	72
The ten commandments of laying	74
Handling and storage	75
Deck fixing techniques.....	76
Cofrastra 40.....	77
Cofrastra 70.....	77
Decks with open ribs: Cofraplus, Cofrasol.....	77
Deck laying.....	78
Standard section floor decks.....	78
Changing floor deck direction	78
Floor decks on intermediate supports	79
Deck ends	80
Rebate laying on reinforced concrete beams ..	81
Threading of main beam	82
Placing props.....	84
Bearing on brickwork	85
Overhang	86
Trimmers and floor openings.....	87
Composite beam - connectors.....	88
Laying of Cofradal 200.....	89

Arval

Building



Sport City Tower, Doha (Qatar)

ARCHITECT: Concept Architect

Hadi Simaan, Florida (USA)

STRUCTURE: Arup, London (United Kingdom)

the key benefits of Arval floor systems



Formwork function and speed of implementation

Arval floor systems serve as a self-supporting formwork, they resist construction loads and concrete weight, they are simple and quick to lay, and the easy cutting and quick interlocking of the ribs contributes to site productivity.

A finished and sealed underside

Arval floor systems, once in place, present an underside with a finished, clean, sealed appearance which can be left uncovered.

There are a choice of two finishes:

- galvanised underside: this is ideal for intermediate floors in ventilated buildings and terraces.
- precoated underside: the prelacquered coat improves resistance to corrosion, prevents patina on the galvanised surface and gives the underside a decorative appearance. This is recommended in buildings where the soffit is exposed as a ceiling and in car parks where they bring light and safety.

A floor bringing safety to the work site

The laying of Arval floor systems creates a continuous working platform that allows site workers to walk over several complete levels of the construction straight away.

The floor can be safely walked on once it is fixed to the supports.

Overall savings

Implementing factory-produced industrial systems using expert technology and an acknowledged speed of laying brings substantial savings in terms of construction costs compared to a reinforced concrete floor.

The hollows between ribs reduce concrete consumption by up to 100 kg/m².

Savings in reinforcements may reach up to 6 kg/m² compared to a solid concrete slab. The lightness of the Arval floor systems provides structural savings (one or two beam sections) and foundation savings, and also enables easier renovation, modification or extension of buildings.

Fire behaviour

All of our solutions provide a firestop response of up to 3 hours. Actual fire tests performed at scale 1 at the CNPP (national prevention and protection centre) in Vernon, demonstrated exceptional performance with no collapse using Arval steel solutions.



Arval floor system offer

Arval benefits from acknowledged experience in the design and manufacturer of floor systems for the construction of buildings and offers the most comprehensive range available on the market.

Our company has the advantage of three decades of experience in this field, with know-how manifested not only in the technical and economical performance of the floor systems but also in the quality and reliability of the services offered to its customers. We have completed many international projects.

A range of solutions adapted to floors

Arval floor systems are made up of galvanised decks or galvanised-precoated decks.

These profiles, carefully combined with materials such as concrete, thermal- and acoustic-insulation, plaster, and wood, form advanced construction systems intended for all types of structures where their effectiveness and reliability is proven.

Arval floor systems are used in all girder structures or support walls:

- steel,
- reinforced or prestressed concrete,
- brickwork load-bearing walls,
- wood.

The very wide range of Arval floor solutions responds to all your requirements

Four families of Arval floors are available according to the requirements and final use of the building:

- floors on self-supporting permanent formwork: Cofrasol
- composite floors: Cofraplus and Cofrastra
- prefabricated floors: Cofradal
- dry floors: Supportsol,

Cofratherm and Supportsol Décibel.

All Arval floors are subject to a specification sheet specifying the spans, loads, and

- scope of application
- definition of regulations
- technical characteristics
- additional stipulations.

These slabs are combined with the floor joists to enable easy construction of 14-18 m clear-span floors for office buildings: globalFloor.

Each floor construction system takes into account the requirements relating to sustainable development. It is environmentally and user friendly.

Arval plays an active role in sustainable construction by using steel solutions that provide a guarantee of safety and comfort to both users and construction workers.

■ FLOORS ON SELF-SUPPORTING FORMWORK

cofrasol

Cofrasol floors are made up of steel decks used to provide formwork for the reinforced concrete when it is poured.

Cofrasol floors are made up of steel decks used to provide formwork for the reinforced concrete when it is poured.

For slabs on self-supporting permanent formwork, the deck is only stressed during the construction stage.

It receives the poured concrete and bears its weight until the concrete sets. Then, the applied loads are borne exclusively by the reinforced concrete slab which is therefore designed for this function.

The steel deck is self-supporting and is no longer taken into account in the final floor resistance.

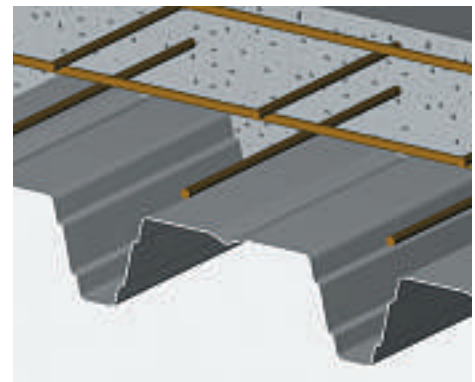

Cofrasol floors are available in a range of four profiles: Cofrasol 39, Cofrasol 40, Cofrasol 60, and Cofrasol 118, depending on the desired span.

These cover many fields of application, such as car parks, offices, and renovation projects.

SYSTEM OFFER

COMPOSITE FLOORS

Composite floor systems combine the beneficial features of steel and concrete. Steel is an excellent material for working under tension and concrete is an excellent material for working under compressive stress.

If the steel deck is made with embossments, these make the concrete slab and the steel decks interdependent and they work together to produce the composite resistance of the floor. We therefore refer to composite floors or slabs.

A composite floor is designed in two different stages: the assembly and concrete-pouring stage, and then the composite stage. During the assembly and concrete-pouring stage, the deck is used as self-supporting formwork and provides a working platform.

In the composite stage, the deck is structurally combined with hardened concrete (composite action) and completely or partially replaces the tensile reinforcement of the slab.

Composite floor decks are used to build floors in fields as varied as offices, housing, industrial buildings, car parks, hospitals, and school buildings, either as new construction or renovation.



Fabrication of a composite floor deck

Open-rib composite floor decks: **cofraplus**

These are made up of two open-rib trapezoidal and nestable decks with embossments for easy storage and transportation. Cofraplus is the best solution for most uses involving spans up to 4.5 m.

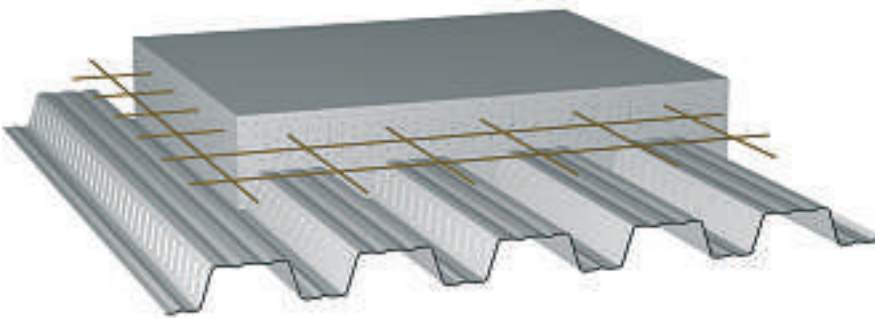

cofraplus 60

Cofraplus 60 guarantees economical transportation and quick installation. The deck is manufactured from 0.75mm gauge steel and is designed for medium spans (up to 3.60m) without props over 2 continuous bays, and slab thicknesses of 10 to 28 cm.

cofraplus 77

Cofraplus 77 benefits from the advantages of the Cofraplus range and takes its performance further.

- It exceeds unpropped spans in the construction stage up to 4.20 m with a thickness of 0.75 mm over two continuous bays
- At an equivalent applied load, it exceeds greater spans in the composite stage and can be laid with slabs with a thickness of 12 to 28 cm.

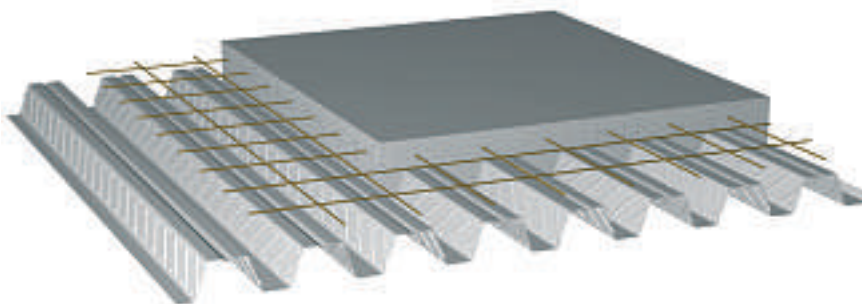

SYSTEM OFFER

Re-entrant-ribs composite floors decks: **cofrastra**

The Cofrastra family consists of two re-entrant notched rib decks to tightly and integrally join the steel and concrete: **Cofrastra 40** and **Cofrastra 70**.

Dove-tail shaped re-entrant ribs:

- can provide anchor lines for suspending ceilings and technical networks using Cofrafix clips fixed in place by hand,
- create a very strong bond with the concrete.

Cofrastra can support substantial live loads and reach spans of up to 7 m.

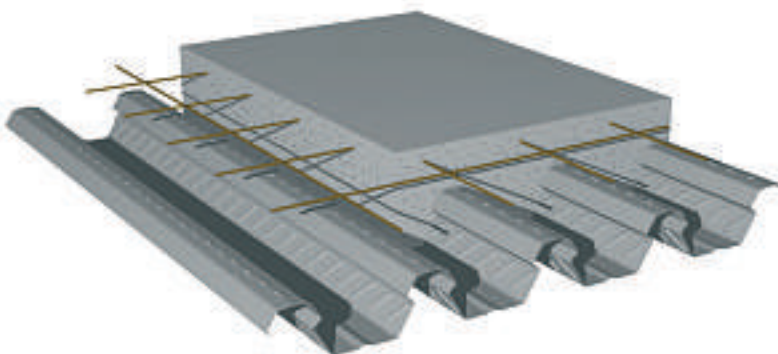
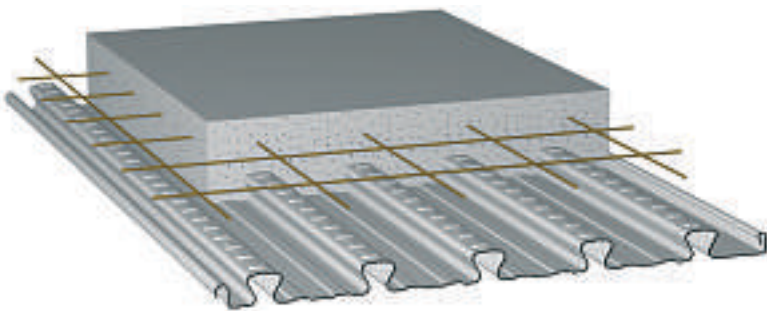

cofrastra 40

- is used to lay very thin (8 cm) or thick (20 cm) floors as it covers practically the entire field of construction with light and heavy loads.
- easy to anchor ceilings using special clips fitted into the closed ribs.
- benefits from very good fire resistance due to its narrow ribs.

cofrastra 70

- is especially adapted to unpropped medium spans.
- can be used with slabs of 11 to 30 cm thickness and can bear very heavy loads.
- aims to lighten structures with heavy dead loads.
- enables suspension of ceilings using special clips fitted into the closed ribs.

Multi-functional composite floors: **cofrastra décibel**

Cofrastra Décibel is a multi-functional floor combining the best features of its different components.

Cofrastra 40 or Cofrastra 70 decks and the concrete poured on site form a reinforced composite slab.

The bottom part consists of a suspended ceiling made up of plaster boards and glass wool, which is used as an acoustic insulation material. The presence of glass wool in the plenum space provides the floor with the desired thermal insulation, and the plaster boards provide fire stability, if needed, for the slab and beams.

Cofrastra Décibel offers an advanced global construction solution for collective housing and office floor dividers.

Cofrastra Décibel easily adapts to the regulatory requirements on thermal and sound insulation, and on fire safety.

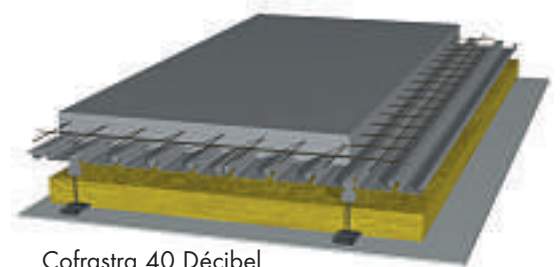

Cofrastra 40 Décibel

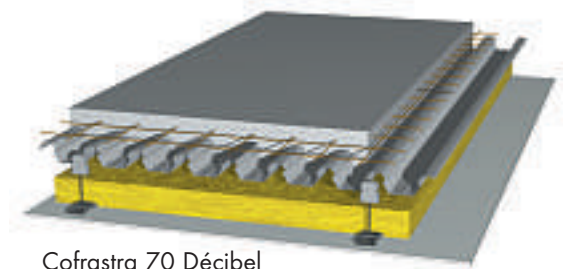

Cofrastra 70 Décibel

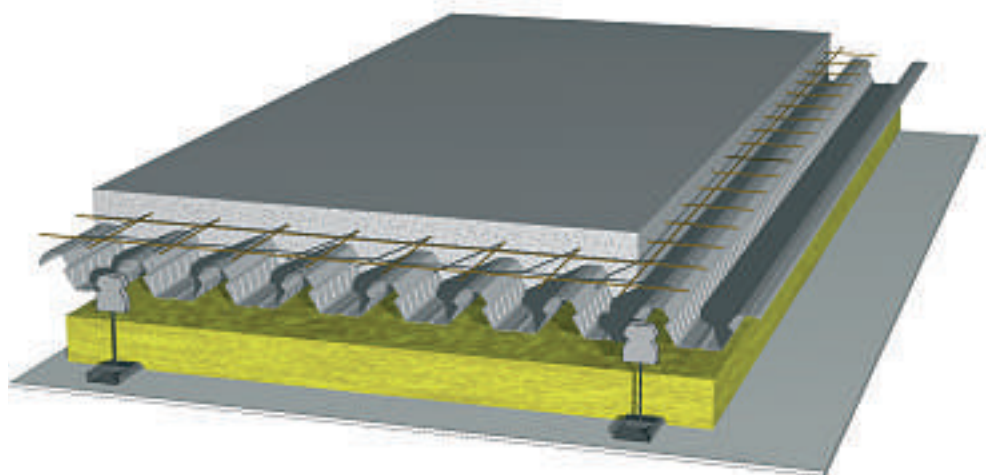

SYSTEM OFFER

■ PREFABRICATED FLOORS

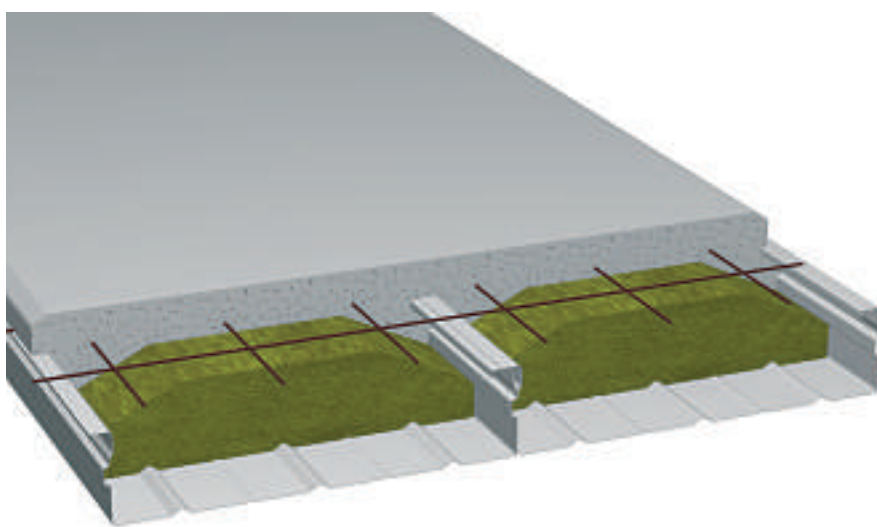

cofradal 200

Cofradal 200 is a floor system that is prefabricated in the factory in elements 1.20 m wide with lengths up to 7 m. It incorporates a specific tray, sound and thermal insulation material, a weldmesh, and a concrete slab.

Cofradal 200 can be supplied without a concrete screed, which is then added on the building site. The underside is galvanised or precoated, and has a flat and clean surface.

With a dead weight of 200 kg/m², this ultra-light floor system offers considerable savings in steel weight of the framework.

It is also the ideal solution for fast implementation without props as it dispenses with pouring of the slab in situ. Cofradal covers an unproped span of 7.0 m.

A Cofradal 200 PAC version ready to pour on site (hand-portable version in elements of 600 mm) is available. This version is particularly suited to the renovation market.



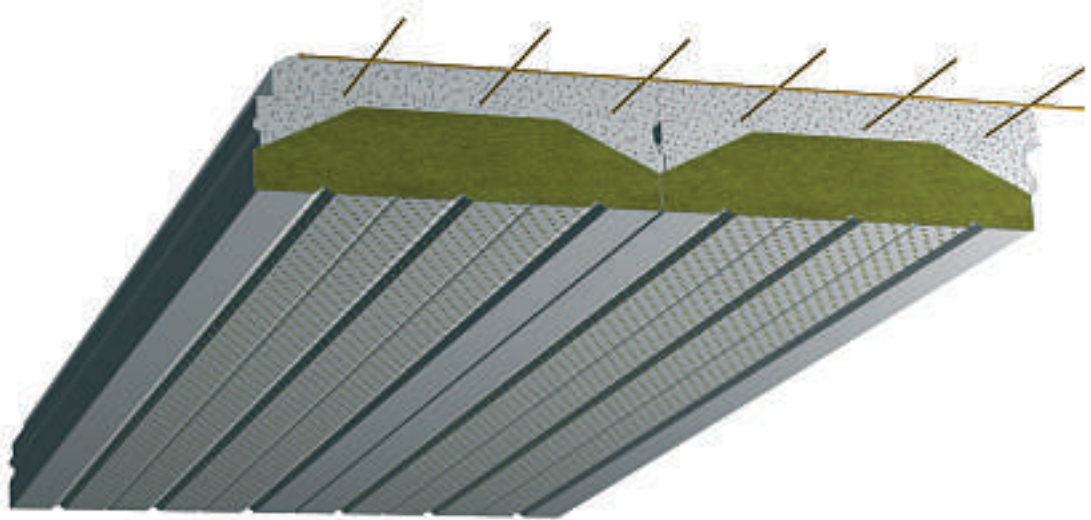

cofradal 200 décibel

In this form, the underside of the steel tray is perforated, thus giving the construction system excellent sound absorption properties.

There are many possible fields of application, such as schools and offices.

SYSTEM OFFER

■ DRY FLOORS



supportsol

In the dry floors product line, steel is a natural partner of wood.

The Supportsol range consists of trapezoidal-rib profiles, with wooden decking panels screwed onto the rib crowns to form an uninsulated dry floor.

The performance is provided by the steel profile only; the rigidity contributed by the wooden panels is not taken into account.

The range is made up of five profiles:

- Supportsol 40,
 - Supportsol 56,
 - Supportsol 74
 - Supportsol 118
 - Supportsol 170
- for spans from 0.8 m to 4.5 m for applied loads of over 13 kN/m².

Supportsol is particularly useful in modular construction.

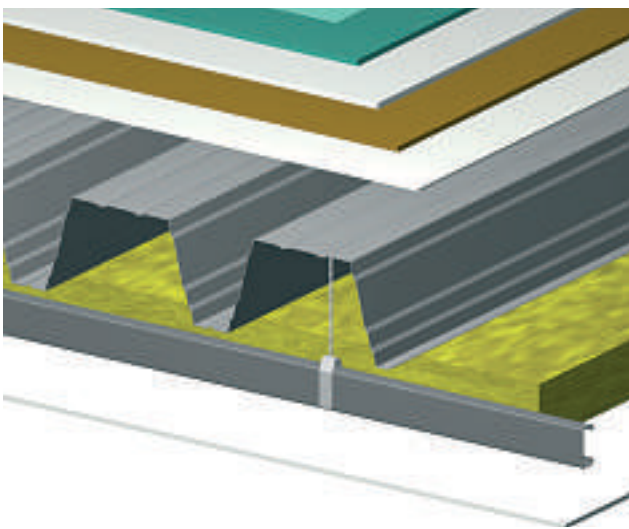

supportsol décibel

Supportsol Décibel is an insulated dry-composite-floor system with a maximum span of 6 m.

It consists of a 200mm deep steel profile with laminated wood panels screwed onto the top of the tray, a glass surfacing mat and a dry screed of plaster boards. The underside is made up of a suspended ceiling in the form of plaster boards, with glasswool introduced into the plenum space.

It has many applications, including renovation, extensions, housing, and offices...



cofratherm

Cofratherm is an insulated dry floor made up of a Cofrastra 40 deck with thermal insulation material placed in the upper part of the assembly.

Insulation is formed by injecting a polyurethane-foam layer into the re-entrant ribs of the deck. The top finish, which provides the walking surface, can be of wood fibreboard or fibre-cement sheet depending on the final use.

It has many uses outside the field of modular construction, such as renovation and building extensions.

the decisive advantages of Arval floor systems

Cofrasol, Cofraplus and Cofrastra floors

- **Low weight – easy to handle**

The steel trays are easy to lift and manoeuvre as they are rigid, light, and easy to grasp by the ribs.

There is typically no need to use heavy lifting equipment for lengths up to 10m.

The trays are delivered on pallets, which ensure easy transportation, handling, and storage on site.

- **Ease and speed of installation**

The decks are manually laid without difficulty and installation is carried out quickly.

The connections between the decks, the accessories and the load-bearing framework are achieved using traditional fixings.

The formwork for the edge, generally comprised of edge trims made from fabricated galvanised-steel sheet, is quickly attached.

- **Well adapted to complex architecture and irregular shapes**

Cutting the decks along an edge at a skewed angle or around a column is carried out as work progresses using shears, nibblers, or saws. This is simple, and precise. It is also possible to adjust the formwork at minimal expense.



Cofraplus and Cofrastra composite floors

- **Reinforcement bar gain**

The closed and/or notched form of the ribs connect the steel and concrete together. The natural reinforcement created by the deck enables bar reinforcement to be omitted from the concrete. In common applications, it is sufficient to add an anti-crack mesh. The equivalent saving is between 2.2 and 6 kg of steel per m² of floor.

- **Composite construction by connection of the composite slab with the steel frame by shear studs**

The connection of the composite slab with the steel or concrete beams provides substantial savings in steel or concrete, and can considerably reduce beam dimensions (up to 35% for floor joists).



- **Horizontal bracing of the structure**

Fixing decks during laying contributes to the bracing of the supporting beam and joist arrangement.

Cofrastra high-bonding composite floors

- **Easy suspension of services and suspended ceilings**

- **Guaranteed thermal and acoustic insulation performance**

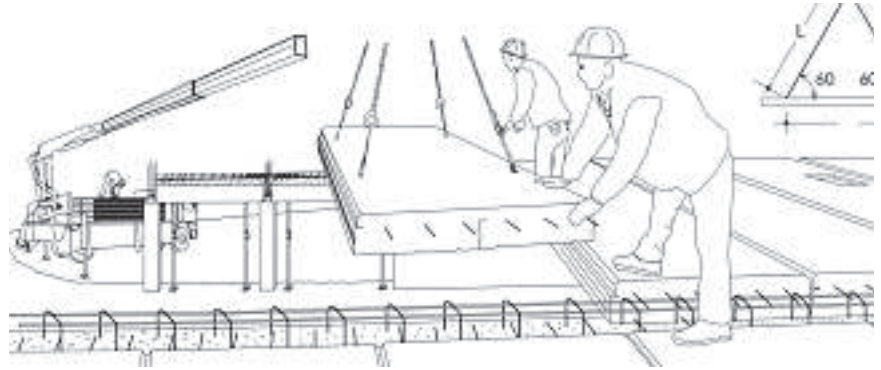

Prefabricated floors: Cofradal 200

- **Substantial dead weight saving**
Cofradal cleverly combines the properties of steel and concrete. The steel, which works under tension, is placed at the bottom of the slab, and the concrete, which works under compression, is placed in the upper part. The floor is considerably lightened which leads to a substantial reduction of the structure and foundation dead weight.

- **Floor ready to lay with spans of 7 m without props**

- **Easy drilling of the underside for fixing of suspended ceilings and services**

- **Easy organisation and management of building site**



- **Considerably shorter construction times**

- **Quick access for other building trades**

- **Guaranteed thermal and acoustic insulation performance**

- **Very good fire stop performance**

Dry floors

- **Management and organisation of the building site made easier owing to the absence of concrete**

- **Manual handling - Lightness - Cleanliness - Economic transport**

- **Adaptable to the technical and architectural requirements of projects**

reference projects

From basic buildings to complex edifices, Arval floor systems are used in all construction fields.

They are an increasingly attractive option to designers, developers, contractors, and clients because of their many advantages.

The systems particularly respond to requirements for better control over costs and installation time.

Arval's offer is extensive enough for an optimal solution to be found which can be adapted to all applications.



Quai Branly Museum, Paris (France)
ARCHITECTS : Ateliers Jean Nouvel

RENOVATION

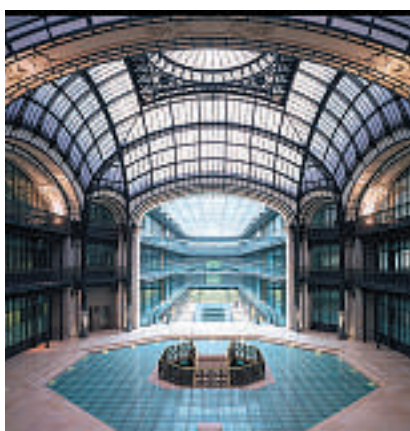

Arval floor systems are particularly valued for renovation of old buildings.

They are therefore often laid in listed buildings located in large cities as it is possible to change the layout of the building storeys without increasing costs. The external walls are conserved while a new structure takes shape inside the building.

The reduced dead weight of Arval floor systems compared to a solid slab is of real benefit when the allowable loads on supporting walls and foundations are limited. The ease of cutting is also very valuable in renovation as it is possible to follow the irregular shapes of walls and to skirt obstacles.



The steel decks that make up the floor are inserted manually through window openings, and the great ease of handling make them the only sensible choice, given that heavy lifting machines are not possible in this case.



Photo on top:
Head office of Crédit Lyonnais, Paris (France)
ARCHITECTS: Architecture studio Jean-Jacques Ory

Photo below:
Chaussée d'Auderghem Building, Brussels (Belgium)

Photo on right side:
Hôtel Dieu, Poitiers (France)
ARCHITECT: Georges Duclos

REFERENCE PROJECTS

ELEVATED CAR PARKS

Arval floor systems are used in the construction of elevated car parks located near airports, shopping centres, hospitals, train stations, etc.



This type of construction is linked to a growing need resulting from the development of urban public transport and particularly commercial centres. The composite steel-concrete product line is particularly suited to the construction of this type of column/beam structure.

The floor beam spacing of 2,5 m, 5 m, 7,5 m or 10 m, corresponds respectively to 1, 2, 3, or 4 car parking bays, and the deck spans in general are 2,5 m. The span of the beams is from 15 to 16 m, and the assembly allows for large areas clear of columns for parking and driving.



Photo on top:
Car park Carrefour, Aix-les-Milles (France)
ARCHITECTS: Sud architectes (Y. Melia)

Photo below:
Car park of Hospital centre, Luxemburg
ARCHITECTS: Gubbini & Linster

The decks are laid continuously and without props. Shear studs are welded to the joists to create a connection between the slab and the girder. The concrete is taken into account when calculating the inertia of the joists.

This construction procedure is used to reduce the section and the floor-space requirement of the joist section.

Arval floor systems avoid the access problems caused by lifting machinery once the steel framework has been laid.

It is a rational, fast, and economical form of installation.



Photo on top:
Car park Hospital centre, Luxemburg
ARCHITECTS: Gubbini & Linster

Photo below:
Car park Auchan, Amiens (France)
ARCHITECTS: Richard Jacques architecture

REFERENCE PROJECTS

■ UNDERGROUND CAR PARKS

Arval floor systems are used to build underground car park floors in large cities.



Depending on the nature of the soil, the construction progresses from the lowest level (in the case of a strong soil) upwards, or from the highest level downwards (in the case of loose soil).

The ease of handling of the decks in this case is a fundamental criterion given the difficulty of working with heavy handling machinery. Their use is essential particularly when starting construction at the top.

Car park Cité Internationale, Lyon (France)
ARCHITECTS: CRB Architectes

REFERENCE PROJECTS

Underground car parks may have circular ramps. In this case, the deck ends are cut at a skewed angle directly in the factory.

In this manner, the decks connect the inner ring and the outer ring using reinforced concrete beams poured on site.

The great adaptability of Arval floor systems to technical and architectural requirements work wonders in a scenario such as this.



Photo on top:

Car park Lazare Goujon, Villeurbanne (France)

ARCHITECTS: Demichel & Dordilly

Photos below:

Car park Saint-Georges, Lyon (France)

ARCHITECTS: Cabinet Governor

REFERENCE PROJECTS

OFFICE BUILDINGS

The overall weight reduction and the savings in steel and concrete contributed by Arval floor systems bring value to all column/beam type structure projects such as office buildings.

The overall weight of Arval floor systems is considerably less than that of common concrete slabs, and those with integrated thermal and acoustic insulating properties offer better soundproofing to both airborne noise and impact noise.



Espace Pétrusse, Luxembourg
ARCHITECT: Marc Werner

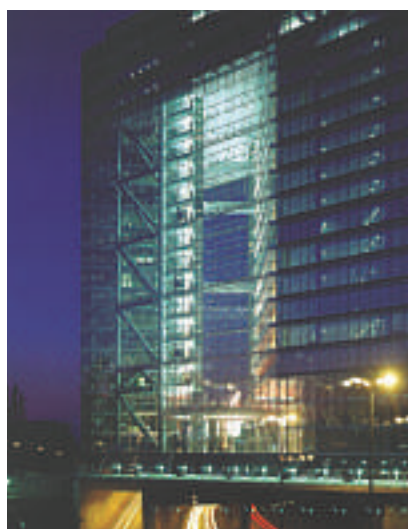

Stadttor, Düsseldorf (Germany)
ARCHITECTS: Overdiek, Petzinka & Partner



Tour Madou, Brussels (Belgium)
ARCHITECTS: Assar/archi 2000

In wide-span office blocks without intermediate columns and large clear spaces, the structure and the slabs of composite steel-concrete construction are used to produce low-thickness floors with reduced beam sections.

The combination of castellated joists simplifies the routing of service and reduces the total depth of the floors.



Photo on top:
Le Colisée II, Paris (France)
ARCHITECTS: Skidmore, Owing & Merrill ;
Architecture et Communication

Photo below:
7 place d'Iéna, Paris (France)
ARCHITECTS: Agence d'architecture
Anthony Béchu

REFERENCE PROJECTS

■ ACTIVITY BUILDINGS AND COMMERCIAL CENTRES



Mercedes Benz center, Rueil-Malmaison (France)
ARCHITECTS: M. Macary, L. Delamain

The robustness of Arval floor systems makes them suitable for building floors with heavy and very heavy live loads.

In activity buildings, they have multiple uses particularly as storage floors, mezzanine floors, or divider floors.

The joists are sufficiently close to be able to dispense with propping.

Arval floor systems also offer good performance under live loads for vehicles (e.g. forklift trucks).

This performance, in conjunction with the simple creation of floor openings, makes them naturally suited to floors in production and storage areas.



Building E. Placenet,
Saint-Martin-Boulogne (France)
BET: Maning

REFERENCE PROJECTS

RESIDENTIAL BUILDINGS



Arval floor systems possess all the performance specifications required to divide buildings into compartments meeting the relevant fire, thermal and acoustic regulations.

The Cofradal 200 and Supportsol Décibel floor systems are particularly ideal for buildings with supporting hollow-brick or cement-block walls as a result of their flexibility of use.



Photo on top:
Villa, Pessac (France)
ARCHITECTS: Cabinet Baudin et Limousin

Photo below:
Villa, Villeneuve-lès-Avignon (France)
ARCHITECTS: Patriarche & Co

■ NON-RESIDENTIAL BUILDINGS: MEDICAL CENTRES, SCHOOLS, INFRASTRUCTURES...

Arval floor systems are often laid in structures intended for non-residential buildings.

The great adaptability of the floors to architectural requirements and the great freedom they allow in project design are highly valued by architects and designers.

Right, on top:
Court House, Grenoble (France)
ARCHITECTS: Vasconi associés architectes

Right, below:
Sport Centre Paul-Valéry, Paris (France)
ARCHITECTS: Atelier J. Bardet - P. Richard - J. Soucheyre

Photo below:
Hôpital de la Mère et de l'Enfant, Nantes (France)
ARCHITECT: Rémy Butler



sustainable development

■ THE HIGH ENVIRONMENTAL QUALITY INITIATIVE

The HQE® initiative brings real added value to the building and must therefore be used as a factor to enable the client to differentiate and foster loyalty among the occupants, which is a challenge for private and public rental-housing managers.

The HQE® initiative therefore fully contributes to quality, which has been a real commercial advantage for several years.

The Arval floor solutions are allied to the HQE® initiative.

In this context, where environment, health, and economy are increasingly interconnected, steel has many advantages.

It is recyclable, durable, strong, and also neutral from a health point of view, and thus proves everyday that it is capable of matching the level of the most inventive and successful architectural procedures, and adapting to the most exacting implementation conditions, particularly with regard to building-site nuisance. This potential makes steel an ally of the HQE® initiative.

The prefabrication of steel construction elements in the factory reduces building-site nuisance to an absolute minimum. The excellent weight/strength combination of Arval floor systems offers a very wide range of architectural possibilities and renders light structures possible, thus leaving a large area open to light and harmoniously integrating into the environment.

Arval floor systems provide a multitude of thermal- and acoustic-insulation solutions. Comfort, aesthetics, safety, economy, and resource preservation are some of the many qualities of steel construction and the many advantages in relation to the HQE® initiative.

Low thermal inertia

Arval floor systems lead to buildings with low thermal inertia.

Energy is therefore not wasted in heating the structures. It is also possible to regulate heating needs with a certain amount of flexibility according

to the hours that the building is occupied. This is an advantage for offices at night-time, and houses during the daytime.

Furthermore, it has already been demonstrated that it is possible to construct buildings for daytime occupation without the need for a heating system, by relying on strengthened insulation and drawing on the heat of the sun during the day.

Preservation of resources

The natural mechanical characteristics of steel (particularly a high strength/weight ratio) enable structures supporting light floors to be created in order to gain living space. The minimal depth of the floor systems limits the consumption of raw materials and energy.

The low weight of steel constructions is also advantageous on weak ground, which would require substantial foundations to bear traditional buildings.

Flexible and adaptable

Sustainable development is concerned with the needs of future generations. Arval floor solutions make it easy to remodel spaces according to changes of use and changes to family structures, while reducing environmental impact (e.g. waste, energy consumption).

These solutions allow for renovations such as extensions, rehabilitation, or adapting to new/changed regulations (e.g. strengthening or adding a stair well).

Integrated choice of construction procedures and systems

This is probably the area of the HQE® initiative where the contribution of steel is most tangible.

The reason for this is that Arval systems participate in this resource-saving logic by fulfilling the required functions with reduced consumption of raw materials.

Recyclable and recycled material

Steel can be 100% recycled indefinitely, without any alteration to its qualities. It has unequalled magnetic properties that enable it to be separated and recovered from waste of any kind. The percentage of steel production worldwide resulting from recycling scrap is 40%. The same applies to preserved ore (even though iron ore is one of the most abundant elements in the Earth's crust), resulting in reduced energy consumption and therefore greenhouse-gas emissions.

Durable material

With metal coating (galvanising) and/or paint systems to protect against corrosion, steel retains its properties over the entire lifetime of the structure and ensures its longevity. Steel ductility is also a major advantage against earthquakes. The damage suffered by structures subject to earthquakes is minimised, the risk of collapse is eliminated, and human life is saved.



how to choose the most suitable system?

Arval floor systems stand out for the advantages they offer in terms of reduced weight, speed of installation, cost savings, and resistance in the most varied applications where they are employed as a natural complement to the framework.

Installation of a prefabricated floor



On site concrete pouring of the slab

- **Service floors**
 - industrial production buildings
 - commercial buildings
 - elevated and underground car parks
 - warehouses
- **Compartment floors**
 - office buildings
 - collective and individual housing
 - health and leisure homes, hospitals
 - schools
 - renovations

Choice guide

The best solutions must be chosen according to the problem posed, and the technical and economic constraints.

The “Common solutions choice guide” is a quick search aid for the Arval floor system most suited to the project requirements.

The Arval sales and technical assistance teams are at your disposal to help you choose the best solution for your project and the associated specifications.

Common solutions choice guide

Buildings	Structure		
	Concrete and Masonry	Metal	Wood
Industrial Buildings Warehouses	Cofrastra Cofraplus, Cofrasol	Cofrastra Cofraplus, Cofrasol	Cofrastra Cofraplus, Cofrasol
Office	Cofrastra, Cofradal 200 Décibel Cofraplus, Cofrasol, Cofradal 200	Cofrastra, Cofradal 200 Décibel Cofraplus, Cofrasol, Cofradal 200	
Schools	Cofraplus, Cofrastra Cofrasol, Cofradal 200	Cofraplus, Cofrasol, Cofradal 200	
Medical Centres	Cofraplus, Cofrastra Cofrasol, Cofradal 200	Cofraplus, Cofrastra Cofrasol, Cofradal 200	
Collective Infrastructures	Cofraplus, Cofrastra Cofrasol, Cofradal 200	Cofraplus, Cofrastra Cofrasol, Cofradal 200	
Commercial Centres	Cofraplus, Cofrastra Cofrasol, Cofradal 200	Cofraplus, Cofrastra Cofrasol, Cofradal 200	Cofraplus, Cofrastra Cofrasol, Cofradal 200
Collective Housing	Cofrastra Décibel, Cofradal 200, Supportsol Décibel	Cofrastra Décibel Supportsol Décibel	
Individual Housing	Cofrastra 40 Cofraplus, Cofradal 200	Cofrastra 40 Cofraplus, Cofradal 200	Cofrastra 40 Cofraplus 60, Cofradal 200
Renovation	Cofrastra 40, Cofraplus Cofrasol	Cofrastra 40, Cofraplus Cofrasol	Cofrastra 40, Cofraplus Cofrasol,
Car Parks	Cofraplus, Cofrastra 70 Cofrasol	Cofraplus, Cofrastra 70 Cofrasol	

Use	Structure		
	Concrete and Masonry	Metal	Wood
Modular Construction		Cofrastra 40 Cofratherm	Cofrastra 40 Cofratherm
Dry floors		Supportsol Supportsol Décibel	Supportsol Supportsol Décibel
Flat roofs	Cofrastra 40, Cofradal 200 Cofrasol	Cofrastra 40, Cofradal 200 Cofrasol	Cofrastra 40, Cofradal 200 Cofrasol

The following chapter **Designing** permits to optimise the choice according to the specifications.

Designing

Sport City Tower, Doha (Qatar)
ARCHITECT: Concept Architect
Hadi Simaan, Florida (USA)
STRUCTURE: Arup, London
(United Kingdom)



Arval floor system frames

The spacing of the main concrete or steel beams and joists, which is generally adjustable, varies from 1,5 to 7 m according to the requirements of the project. The span of beams or joists can reach 18 m or more.

The choice of spans and spacing of the beams and joists is optimised for economy according to the project data.



For each frame desired, there are one or more Arval floor solutions suitable for the building-site constraints, the assembly requirements, and the overall cost.

Arval uses its globalFloor software to optimise the beam and slab interaction to identify the most economical solution.

Designers generally prefer to reduce the spacing between joists or beams to avoid having to use propping when laying. The limited unpropped span and the required slab thickness can therefore be used to guide solution selection. For most applications, the imposed load is not a limiting factor in floor design.

Our design software facilitates this economical and technical choice.

These points are illustrated with the help of some examples of general construction projects where an Arval floor system adapted to the specific project data has been selected. (pages 61, 62 and 63)

performance of Arval floor systems

Maximum admissible spans without propping in construction stage

Uniformly distributed loads, equal double span slab and deck, thickness 0,75 mm

	Cofraplus 60	Cofraplus 77	Cofrastra 40	Cofrastra 70
Span Line of props Minimum slab depth	3,60 m 0 10 cm	4,19 m 0 12 cm	2,65 m 0 8 cm	3,73 m 0 11 cm
Span Line of props Maximum slab depth	2,14 m 0 28 cm	2,62 m 0 28 cm	1,95 m 0 20 cm	2,05 m 0 30 cm

Concrete saving and savings relating to the weight of composite slabs

compared to solid slabs

Composite deck	Concrete saving litres/m ² resulting from the ribs space on the underface	Resultant saving in deadweight compared to a solid slab of equivalent depth kg/m ²	Range of dead weight saving in % for a slab thickness from composite slab minimum thickness to 20 cm	
Cofrastra 40	10	24	8 to 20 cm	12 to 5%
Cofrastra 70	24	58	11 to 20 cm	22 to 12%
Cofraplus 60	35	84	10 to 20 cm	35 to 18%
Cofraplus 77	44	105	12 to 20 cm	37 to 22%

PERFORMANCES OF ARVAL FLOOR SYSTEMS

Reinforcement saving achieved by composite slabs

Example of comparison

Fire rating 30 minutes

Imposed loads: 3,5 kN/m², 8 kN/m², 15 kN/m²

Equal double span slab, span 3 m

Deck thickness : 0,75 mm

Span (m)				Reinforcement saving in comparison with a solid slab
3	Imposed loads	3,5 kN/m ²		
	Floor process	Solid slab	Cofraplus 60	
	Slab depth	10 cm	10 cm	
	Flexural Reinforcement	2,24 kg/m ²	/	2,24 kg/m ²
	Imposed loads	8 kN/m ²		
	Floor process	Solid slab	Cofraplus 60	
	Slab depth	11 cm	12 cm	
	Flexural Reinforcement	3,73 kg/m ²	/	3,73 kg/m ²
	Imposed loads	15 kN/m ²		
	Floor process	Solid slab	Cofrastra 70	
Slab depth	13 cm	12 cm		
Flexural Reinforcement	5,2 kg/m ²	/	5,2 kg/m ²	

PERFORMANCES OF ARVAL FLOOR SYSTEMS

Fire stop solutions

Suspended ceilings - Cofrastra Décibel floor without fire-bracing reinforcement bars

Fire stop	Special measures	References
30 minutes	None	Technical approval
60 and 90 minutes	Fire stop ceiling Placoflam® BA13 Placoplatre	CSTB Report Nr. 93.36105
120 minutes	Fire stop ceiling Placoflam® BA15 Placoplatre	CSTB Report Nr. 93.36105

Arval floor system Cofraplus, Cofrastra, Cofradal, Cofrasol performances

Fire stop criteria, acoustic, punching of holes for passage of workshop-welded shear studs fixing of suspended ceilings

	Cofraplus 60	Cofraplus 77	Cofrastra 40	Cofrastra 70
Fire stop	30 minutes without fire-bracing rebar. Up to 3 hours with fire-bracing rebar	30 minutes without fire-bracing rebar. Up to 3 hours with fire-bracing rebar	30 minutes without fire-bracing rebar. Up to 3 hours with fire reinf.	30 minutes without fire-bracing rebar. Up to 3 hours with fire-bracing rebar
Acoustic	**	**	**/** Cofrastra Décibel	**/** Cofrastra Décibel
Punching of holes for the passageworkshop-welded shear stud	Yes	Yes	Yes	Yes
Fixing of suspended ceilings	Drilling	Drilling	Cofrafix or drilling	Cofrafix or drilling

	Cofradal 200	Cofrasol		
Fire stop	30 minutes without fire-bracing rebar. 2 hours and more with fire-bracing rebar according spans and loads	30 minutes without fire-bracing rebar. Up to 3 hours with fire-bracing rebar according spans and loads		
Acoustic	***	**		
Punching of holes for the passageworkshop-welded shear stud	Not necessary	No		
Fixing of suspended ceilings	Drilling	Drilling		

compliance of Arval floor systems with regulations

They satisfy the regulatory framework for each type of utilisation. Arval floor systems use factory manufactured industrial components. Their constant reliability and quality are obtained through systematic and rigorous internal inspection by the manufacturer.

The design, dimensioning and calculation of Arval flooring systems are carried out in accordance with the regulations as laid down in each individual country.

In France for example, the Cofraplus, Cofrastra and Cofradal 200 composite floors are subject to the CSTB Technical Assessment procedure.



In Germany, composite flooring has been given a *Zulassung* granted by the Building authorities (DIBt in Berlin).



COMPLIANCES WITH BUILDING REGULATIONS



The dimensioning and calculation of Arval flooring is, moreover, carried out as per Eurocodes and completed by National Annexes from each country. Eurocodes are the key to the development of modern building techniques in Europe and some countries are already applying them.

An example, that is not exhaustive, is that Arval composite flooring, as used in Belgium and Poland, is covered by a Technical Approval that meets the dimensioning requirements as laid down in Eurocode 4 « Calculation of combined steel-concrete structures».



Floor deck tests
Construction stage

Results of tests carried out and validated in different situations help to design and dimension Arval flooring :

- loading and strength testing,
- tests on shear connectors,
- and fire resistance testing.



Composite slab tests
Composite stage

design criteria



Floor thickness

The floor thickness affects the height of the working floor in situations where there is a limitation on the height of the building.

The minimal thickness of Arval floor systems for imposed loads from 2.5 kN/m² to 10 kN/m² enables the floor space requirement to be reduced as much as possible.

Cofrastra 40 is therefore used to design shallow slabs of 8 cm for spans of up to 2.6 m and imposed loads up to 3.5 kN/m².

It is possible to design floors with reduced floor space requirement by combining Arval floor systems with beams, ACB castellated beams (beams with round holes in the core) or IFB/SFB asymmetric beams.

As a result of their wider bottom flang, these beams are particularly suited to laying floor systems such as Cofradal 200 and Supportsol Décibel floors, which enables them to be integrated into the height of the beam thus eliminating the under-floor sections.

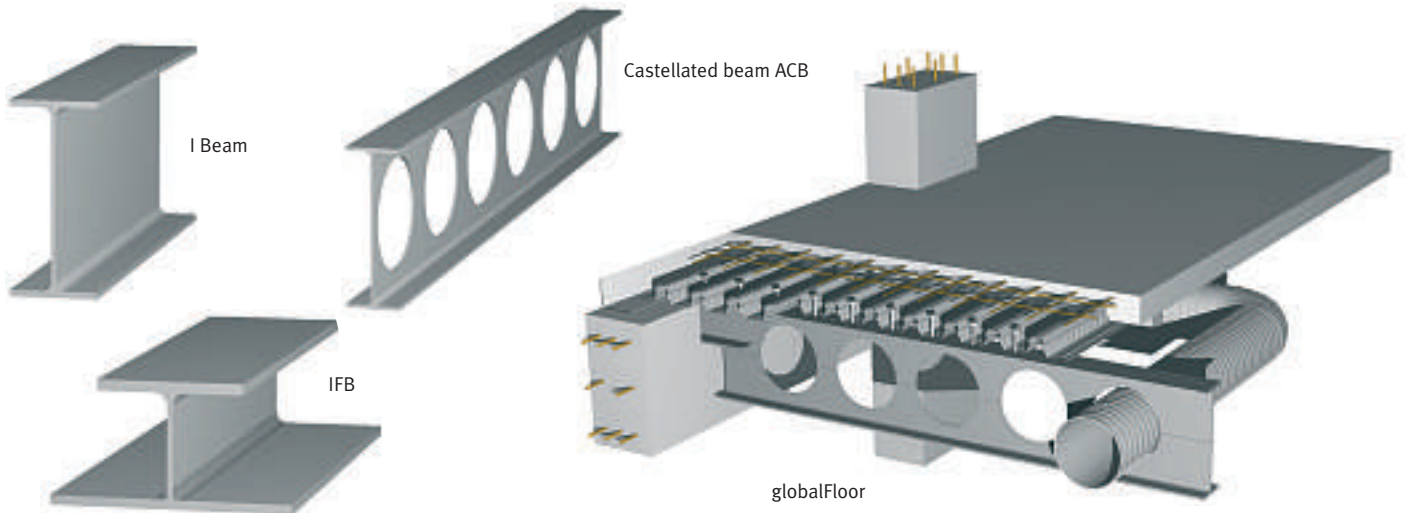

Deflection

- **Deflection criteria during the construction stage.**

The deflection during the construction stage is limited by the regulations.

Eurocodes:

$L/180$, where L equals the span. The effect of increasing the weight of the concrete owing to deflection is taken into consideration when calculating the weight of the wet concrete if the deflection is higher than $1/10$ of the slab depth.

France:

The effect of increasing the weight of the concrete owing to deflection is taken into consideration when calculating the weight of wet concrete.

Arval recommends limiting deflection to $L/300$ for better visual appearance.

- **Deflection criteria during the composite stage under normal loads.**

Cofraplus, Cofrastra, Cofradal 200

Eurocodes:

Eurocode 2 recommends not to exceed a deflection higher than $L/250$ and to establish the appropriate limiting values, taking into account the nature of the structure, the finishes, partitions and fixings and upon the function of the structure.

France:

Slabs not supporting brickwork partitions or fragile floor coatings
 Span $L \leq 3,5$ m, $f \leq L/350$
 Span $L > 3,5$ m, $f \leq 0,5$ cm + $L/700$

Slabs supporting brickwork partitions or fragile floor coatings
 Span $L \leq 5,0$ m, $f \leq L/500$
 Span $L > 5,0$ m, $f \leq 0,5$ cm + $L/1000$

Supportsol, Cofratherm, Supportsol Décibel
 $f \leq L/300$

Natural frequency

The Arval technical assistance team examines particular requirements of natural frequency on request.

DESIGN CRITERIA

REINFORCEMENT

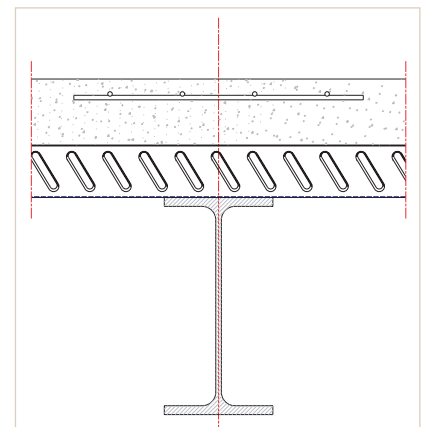
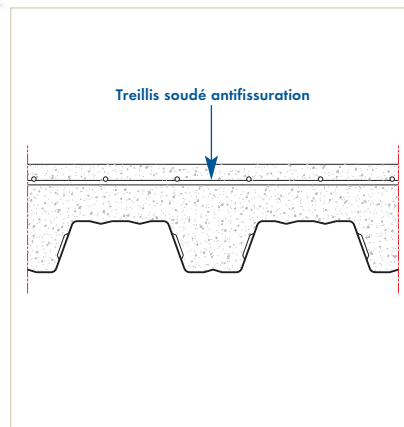
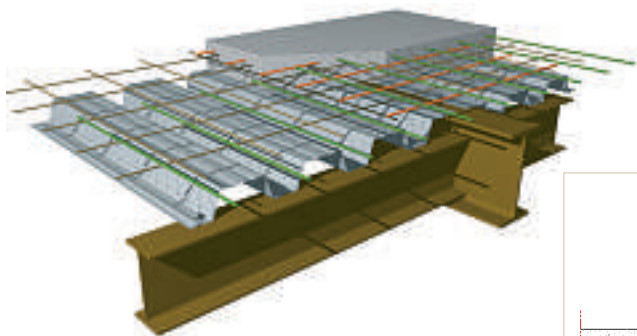

The different reinforcement sections in the following paragraph are dimensioned by using Cofra design software which is available on request.

Anti-crack mesh

It is necessary to introduce a mesh into self-supporting slabs and composite slabs to absorb the forces caused by drying of the concrete during curing.

It reduces and distributes cracking. The mesh is laid 2 cm from the top of the slab. The mesh, on stools, acts as a support for any top reinforcements and contributes to the resistance against negative moments.

Top reinforcements

As with traditional reinforced concrete slabs, top reinforcement on intermediate supports is necessary to absorb negative moments where continuity is taken into account and/or where a fragile floor coating is expected.

These reinforcements, preferably in the form of mesh or rebars connected to the general mesh, cover a minimum area of at least 0,3 times the span L , from one end of the support to the other.

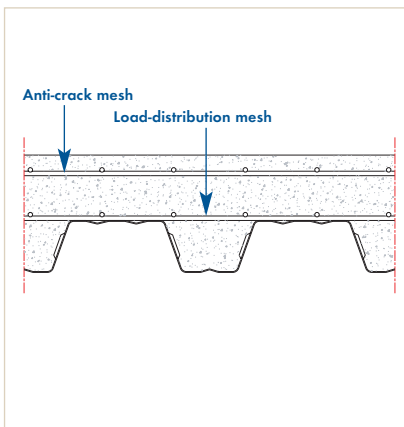

Load-distribution mesh

This is a second mesh used in projects where there are mobile and/or localised loads. It is used to distribute these loads and transmit the forces to the supports.

The load-distribution mesh is keyed to the rib crowns to ensure that the bars are covered.

However, this keying is not necessary if the deck/bar contact is in one spot in relation to the shape of the ribs.

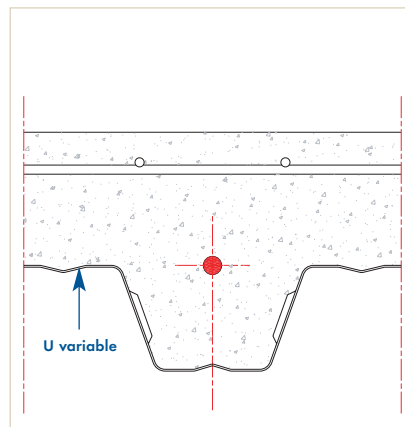

Fire-bracing reinforcement bars

Arval composite floors provide natural fire resistance for 30 minutes.

If more than 30 minutes of fire resistance is required, it is necessary to adjust performance by adding fire-bracing rebars placed into the ribs.

Flexural reinforcement bars

These are rebars placed into the ribs. Their role is to provide strength against bending (resistance or deflection) where the steel section provided by the composite deck is insufficient.

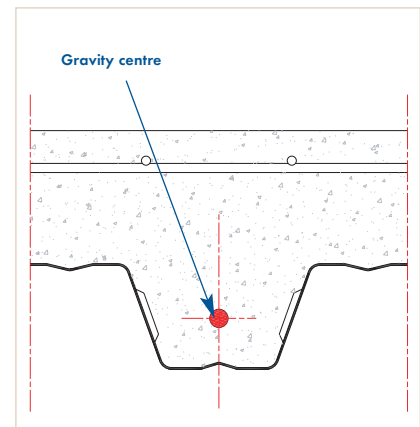

Vertical shear strength reinforcement bars

If the vertical shear strength is greater than the admissible vertical shear strength, it is possible to add reinforcement bars into the ribs, anchored to a support.

These arrangements are only designed for the end-bays.

DESIGN CRITERIA

SUPPORTS STRUCTURES

Arval floor systems can be easily used on steel, concrete, and wood joists and beams, and also on brickwork (load-bearing walls).

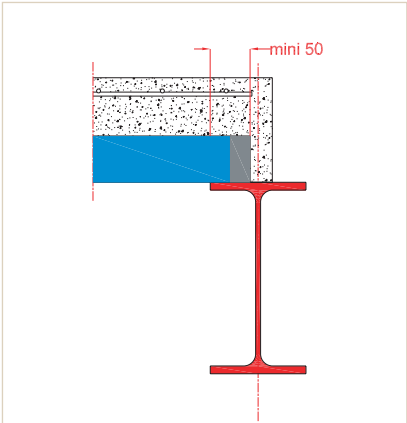

Decking on steel beam

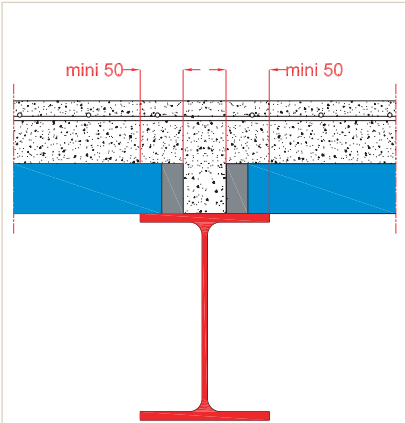

Decking on steel beam

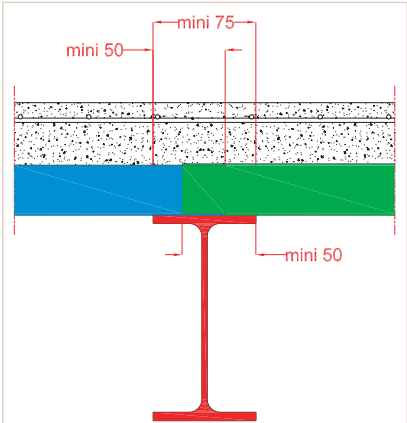

Decking on steel beam

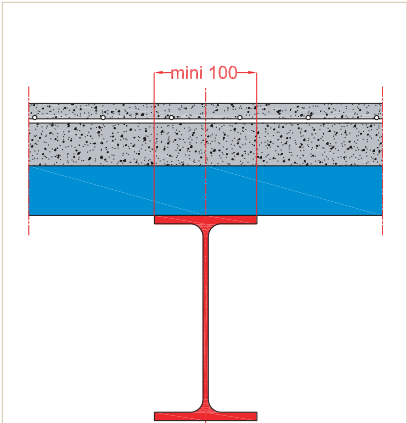

Decking on steel beam

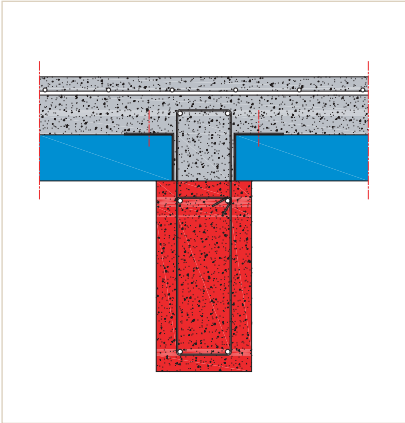

Decking on concrete beam

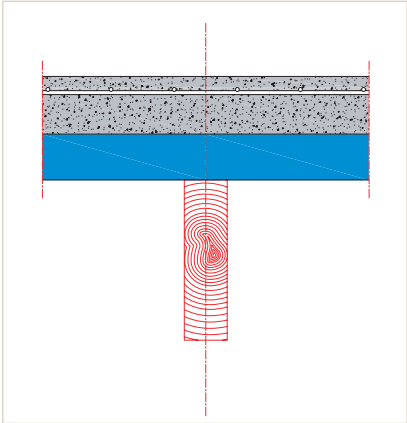

Decking on wood beam

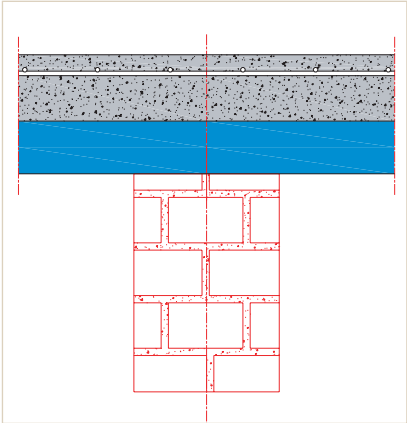

Decking on brickwork

LAYING METHODS

Continuous laying

The decks are laid over several continuous bays. This laying arrangement, known as 'continuous', creates a continuous formwork over the whole building, with each deck covering two or more bays.

Advantages:

Faster laying
Larger spans without props

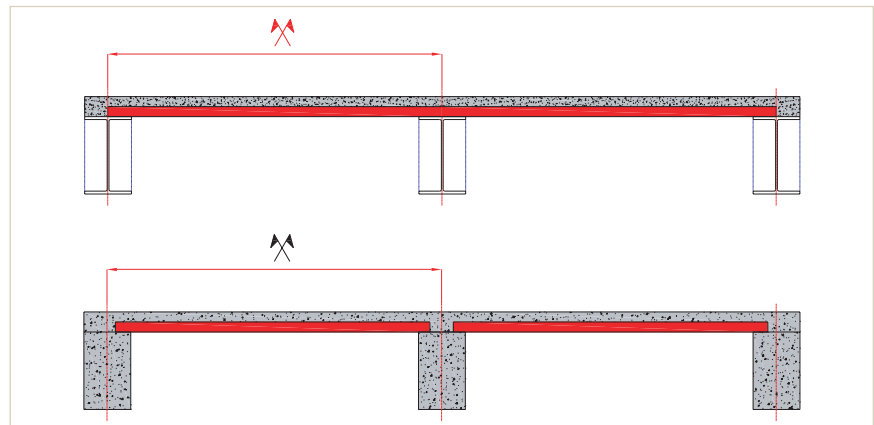

Continuous laying and laying with rebates

Laying with rebates

The decks form a non-continuous formwork, as they stop over each beam. Each deck covers one bay. It rests on a single support at each end.

Advantages:

Easier to hand-carry
Easier laying

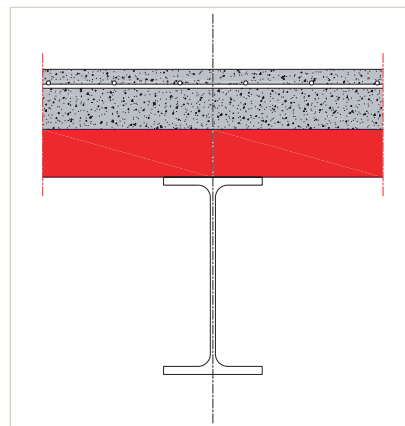

Continuous laying on steel beam

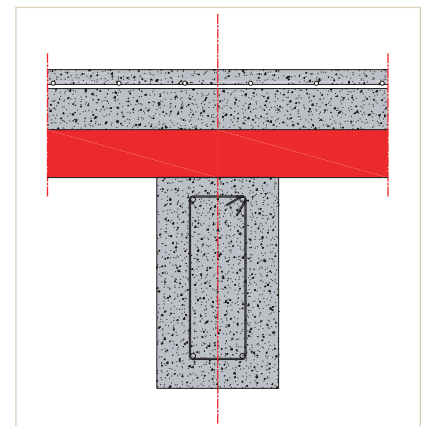

Continuous laying on concrete beam

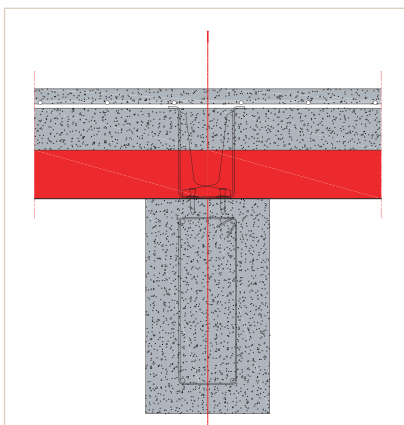

Continuous laying on concrete beam with non-welded connectors

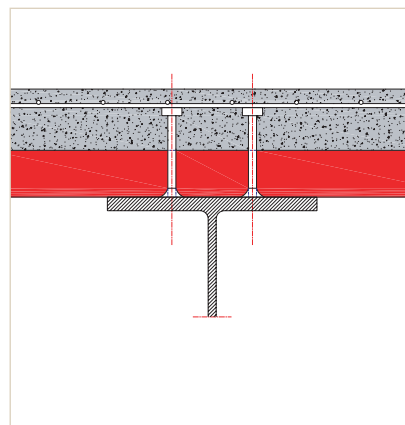

Continuous laying on steel beam with connectors

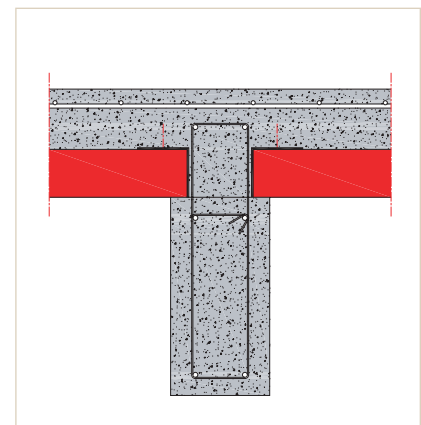

Laying with rebates on concrete beam

DESIGN CRITERIA

■ STEEL GIRDERING

The laying of decks on steel beams equipped with shear connectors is possible. Connectors make it possible to form a steel-concrete composite beam and to optimise the supporting structure.

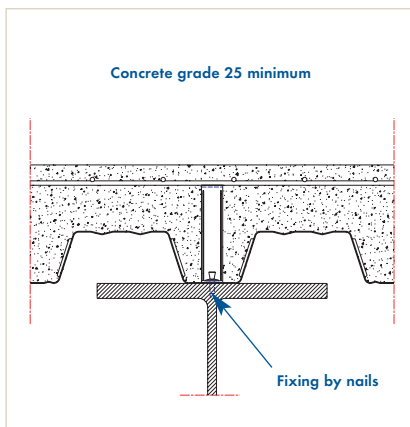
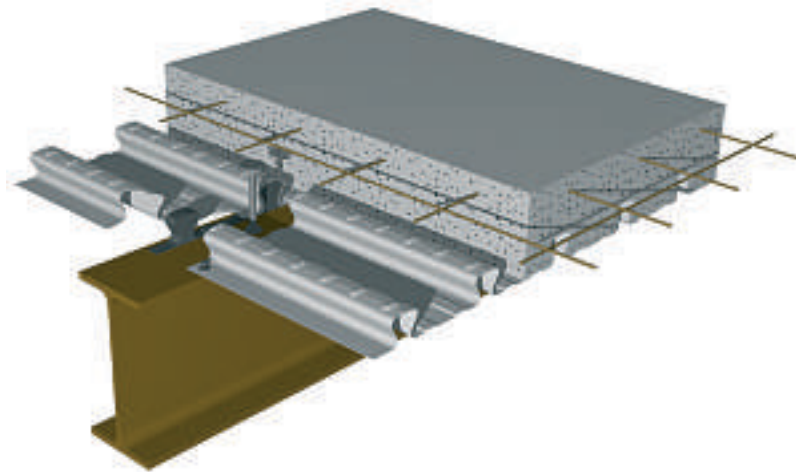

The connectors are designed to create a link between the reinforced concrete slab and the steel beam to create a composite structure. Their role is to transmit the horizontal shear forces acting between the structure and the concrete slab. The laying and the number of connectors arranged along the composite beam are established by design.

There are two connector types available:

Welded shear studs:

The shear studs are welded onto the steel beams either in the workshop or on the building site.

Non-welded connectors:

These are L-shaped cold-formed metal pieces fixed to the beam using two nails shot fired directly into place using a cartridge-operated fixing device.

Advantages

- Important savings in steel weight
- For equivalent span and load values, this procedure substantially reduces the dimensions of steel beams.
- A considerable height saving
- This procedure reduces floor thickness and results in a saving in floor space that can be used to create extra storeys.
- Smaller surface areas to paint or flock
- Increased rigidity of the construction and better seismic stability
- If the height of the steel beams is restricted: gain in span (larger joist spacing).

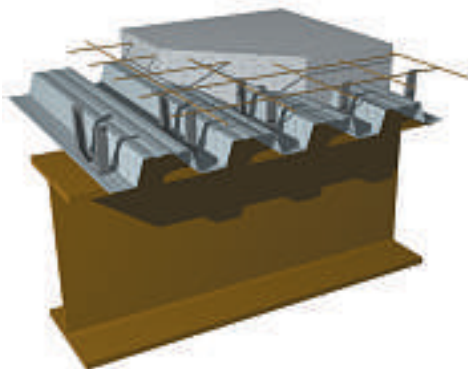

Non-welded connectors

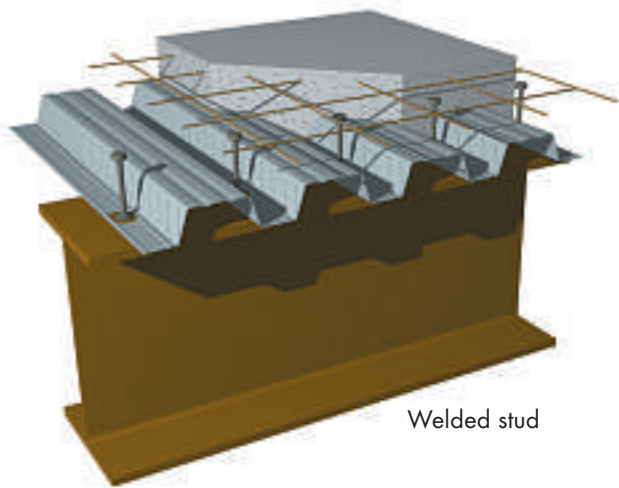

Welded stud

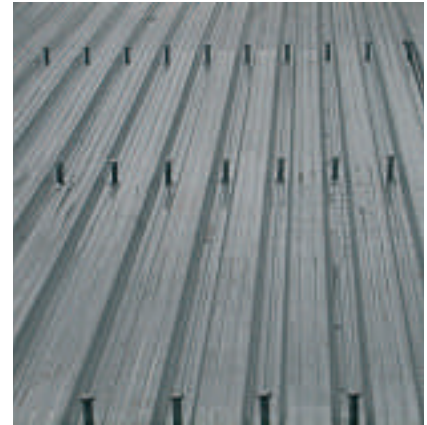

Additional advantages contributed by Cofraplus and Cofrastra in case of welded studs:

- they can be delivered prepunched in factory on request, which saves a lot of time and the connectors can be welded in the best conditions in workshop.

Example 1

Data

- Cofraplus 60 composite deck, 0,75 mm
- Double span slab 3.0 m
- Imposed load: 3.5 kN/m², permanent load: 0.75 kN/m²
- Steel framework: beam spans 14 m

Design calculation made using globalFloor software

Design calculation results

- Beams without connectors IPE 600 beams, weight 122 kg/ml
- Composite beam with connectors IPEa 500 beams, weight 79.4 kg/ml

Saving with connectors

- Beam weight: 42.6 kg/ml, or 35%
- Beam height: 100 mm, or 16.6 %
- Beam protection (paint, flock): 7%

Example 2

Data

- Cofraplus 60 composite deck, 0.75 mm
- Double span slab
- Imposed load: 3.5 kN/m², permanent load: 0.75 kN/m²
- Steel framework: beam spans 14 m
- IPE beams with height of 600 mm

Design calculation made using globalFloor software

Design calculation results

- Beams without connectors Slab span (joist spacing): 3.0 m
- Composite beam with connectors Slab span (joist spacing): 4.3 m

Saving with connectors

- Slab span: 1.3 m, or 43%

DESIGN CRITERIA

CONCRETE FRAMES

The system can be used in concrete frame construction with reinforcement bars prepared to receive the decking and slab. The decks are laid by rebating.

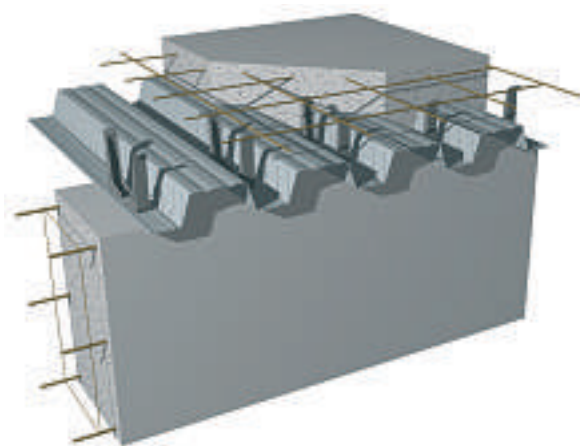

Continuous laying
The connections fixed using nails shot fired permit a continuous laying on concrete beam.

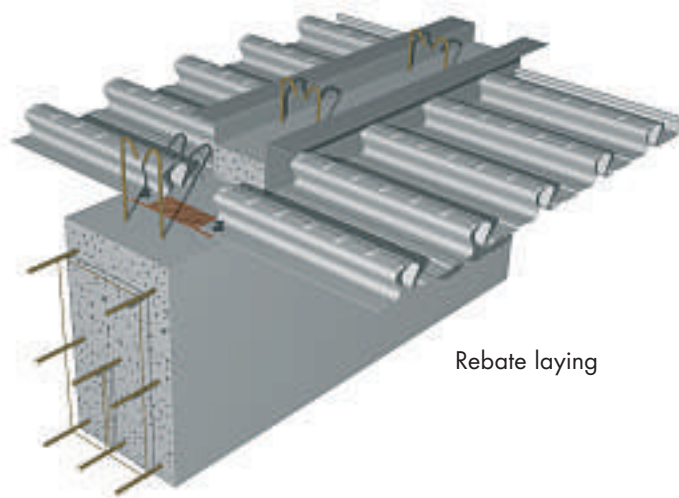

Rebate laying

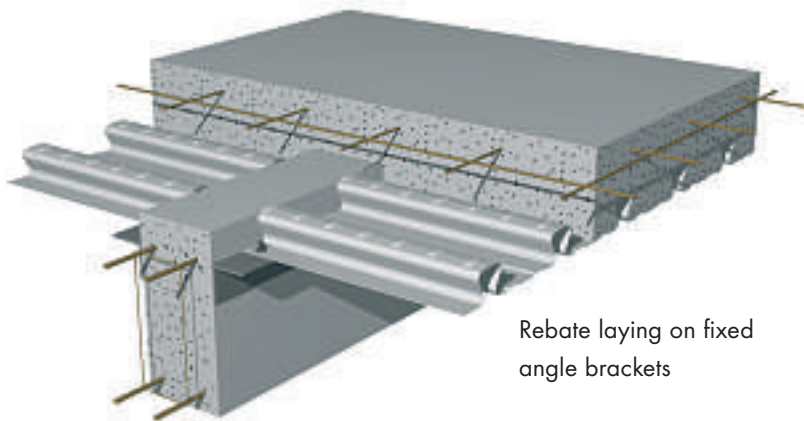

Rebate laying on fixed angle brackets



Advantages

- A considerable saving in concrete weight
- For equivalent span and load values, this procedure substantially reduces the dimensions of concrete beams.
- A substantial height saving

- This procedure reduces floor thickness and leads to a usable floor space gain through the addition of extra storeys.
- **If the concrete beam height is restricted:**
There is a gain in span (larger beam spacing)

FLOOR OPENINGS

Floor-opening can be easily created with Arval floors.

Floor-opening of small dimensions

Floor-opening box-outs of 50 cm x 50 cm maximum, prepared before casting the concrete, can be created using sheet formwork delivered in the required dimensions, by wooden shutter, or by polystyrene block. In this case, the sheet is only cut once the concrete has hardened.

They are reinforced by fixing 50 x 50 x 5 mm corner beams to and in the direction of the ribs from one end of the opening to the other.

There is no need to fit reinforcement if only one rib is cut. If two or three ribs are cut, the lost steel section can be compensated by bars arranged across the opening.

Larger floor openings

In the case of larger floor openings, it is necessary to fit additional structural elements (trimmers).

A floor-opening system made up of transverse and longitudinal angle trims and bearers can also be used. This system, which is integrated into the slab, serves as a trimmer and reinforces the slab around the opening. The different components of the system can be delivered in the required dimensions.

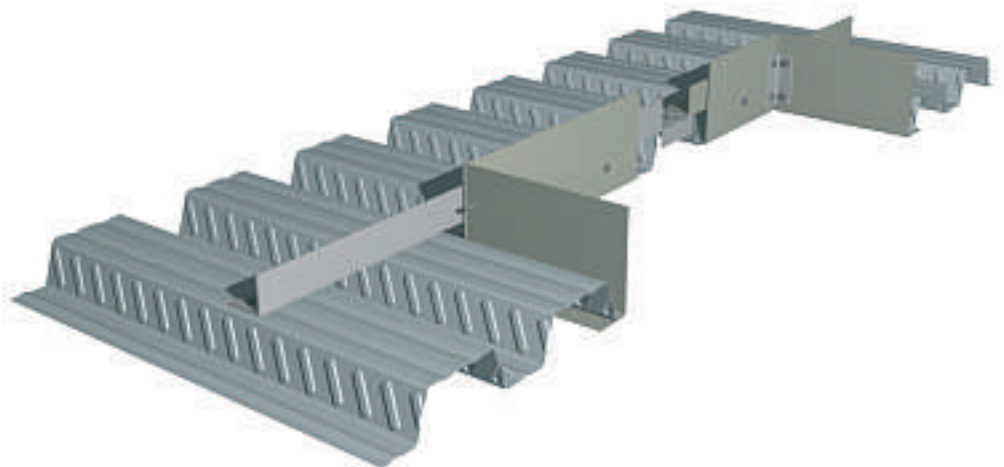
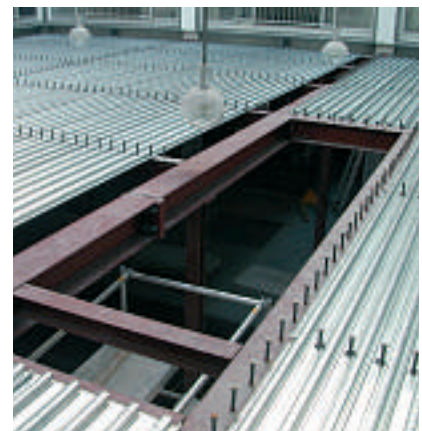

fire behaviour

- Arval floor systems comply with regulations relating to fire safety.
- The concrete-steel combination provides efficient protection against rising temperatures and Arval floors have a natural fire stability of 30 minutes.
- In case of fire, the steel decks prevent the concrete from breaking up and the slab from collapsing.
- The duration of fire resistance can be economically increased up to 2 hours by using additional reinforcements in the concrete within the ribs. In the case of Arval floor systems, the result is always a smaller reinforcement section than is required for solid slabs using identical design assumptions.

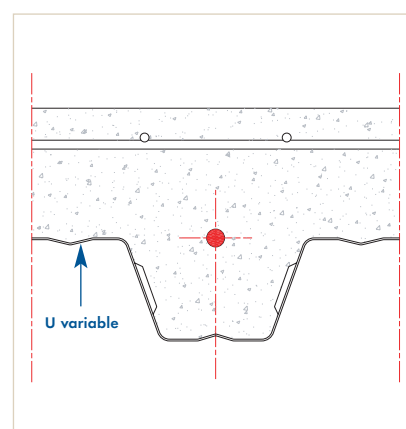
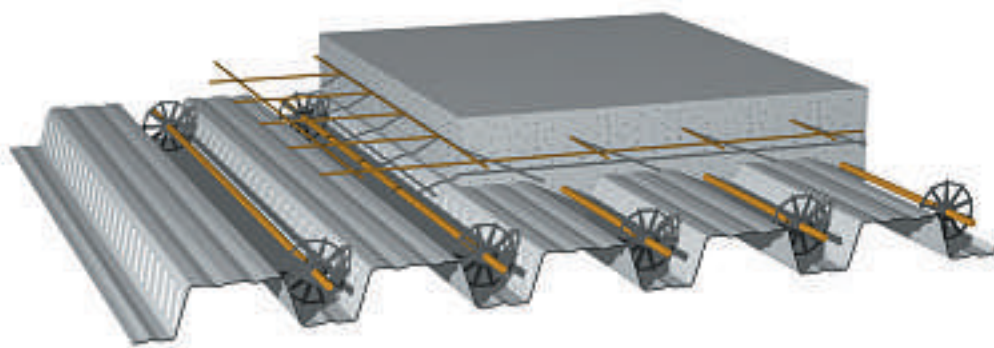

- The fire-bracing reinforcement section and its positioning in the ribs is established by design in application of Eurocode 4.
- These fire-bracing rebars can also serve as cold-flexural rebars.
- The fire resistance requirements also determine the thickness of the slab.
- The fire-resistance duration can also be increased to 2 hours by adding suspended fire-stop ceilings.
- For fire-stop rating greater than 2 hours, it is usually preferable to use protection sprayed on the underside as it is more economical.
- The fire-stop ceiling procedures and sprayed protection provide fire stability to the beams and spare fire-bracing reinforcements.
- Arval floors combined with steel joists have been subject to special fire-resistance tests to validate the behaviour of the joist-beam interaction (CTICM Test-Reports).



acoustic behaviour



Sound insulation

Sound insulation of walls uses two principles:

- The law of mass, which governs acoustic behaviour of homogeneous walls such as concrete slabs.
- The law of mass-damping-mass, which guides the acoustic behaviour of non-homogeneous walls such as Cofrastra décibel, Cofradal 200, Cofradal 200 décibel, and Supportsol décibel floor systems.

The acoustic behaviour of Cofrasol, Cofraplus, and Cofrastra corresponds to the law of mass. These Arval floor systems have a sound reduction index, which is proportional to their mass. These floors have characteristics similar to a solid slab with a thickness equivalent to the average floor thickness.

It is possible to use Arval floor systems governed by the law of mass-damping-mass to obtain superior insulation performance.

Airborne noise insulation (e.g. voices, television, stereo) is therefore obtained using systems combining the slab with a floating screed and a sound-insulation material under the screed laid at the top of the slab, or a suspended ceiling: plasterboards and sound insulation material in the plenum space, such as Cofrastra Décibel.

With regard to impact-noise reduction, effectiveness is obtained by combining either of the two systems described above with a resilient floor covering (e.g. carpets or plastic flooring).

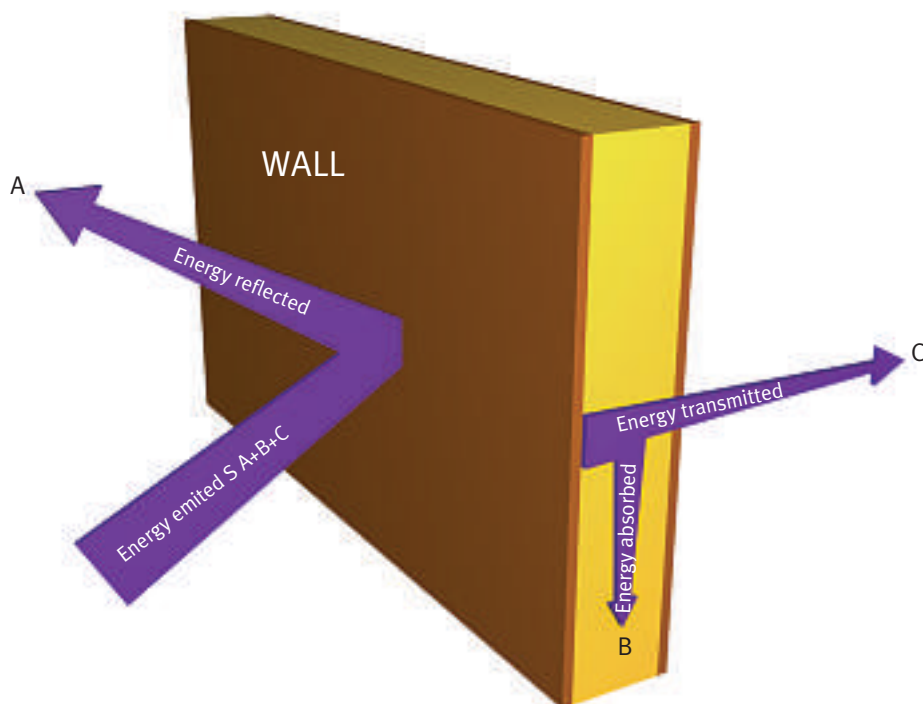

Acoustic performance of the Cofrastra 40 Décibel floor system			
Complex	Rw(C;Ctr)	Ln,w	CSTB Report
Cofrastra 40 + slab thickness 140 mm	51 (-3;-7) dB	79 dB	23268
Cofrastra Décibel, Cofrastra 40 + slab thickness 140 mm + plénum space 70 mm + plasterboard BA13	56 (-6;-11) dB	66 dB	23268
Cofrastra Décibel, Cofrastra 40 + slab thickness 140 mm + plenum space 70 mm + IBR 60 mm + plasterboard BA13	65 (-4;-10) dB	61 dB	23268

Acoustic performance of Cofradal 200 floor system			
Complex	Rw(C;Ctr)	Ln,w	CSTB Report
Cofradal 200 only	58 (-1;-6) dB	78 dB	ID structures AC 04-060
Cofradal 200 with suspended ceiling + glass wool PAR 30 mm from Isover + BA13 from Placoplatre	64 (-2;-7) dB	66 dB	AC 01-133
Cofradal 200 with floating screed + Rocksol 501, 20 mm + dry reinforced screed of 50 mm	72 (-6;-14) dB	49 dB	ID structures AC 04-060

Acoustic correction

Cofradal 200 Décibel

The underside of Cofradal 200 trays can be perforated to meet acoustic-correction requirements.

The absorption coefficient α_w is 0.85.

thermal insulation

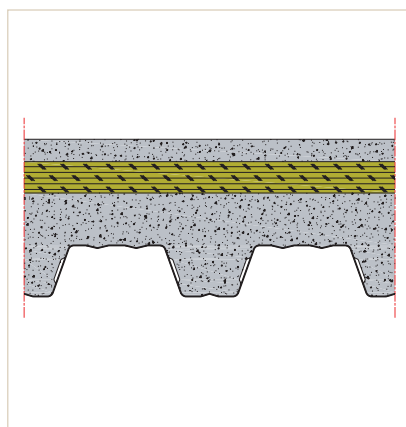

Thermal insulation under screed

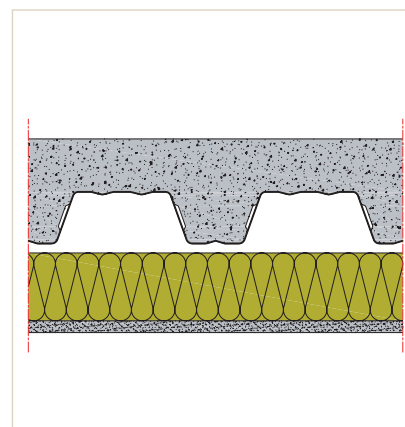

Thermal insulation over ceiling

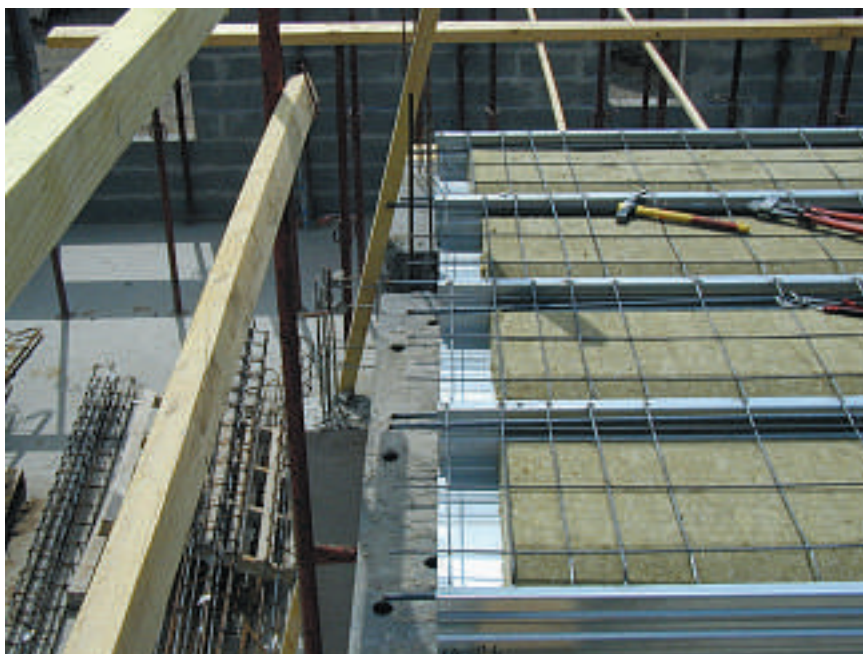

Arval proposes different solutions to deal with thermal insulation decking problems, taking into account the thermal insulation regulations: insert a thermal insulation under the screed or insulation over ceiling.

The choice of suitable materials and their laying conditions takes into account the thermal and insulation regulations (in France: RT 2005).

Cofrastra Décibel A floor thickness of 20 cm, 4 combinations of slab thickness and insulation material and their thermal insulation performance				
Thickness of the composite slab	Thickness of the thermal insulation material	Thermal resistance of the insulation	Thermal resistance of the floor	Coefficient of surface loss of floor U
8 cm	12 cm	3 m ² K/W	3,3 m ² K/W	0,31 W/m ² K
10 cm	10 cm	2,5 m ² K/W	2,8 m ² K/W	0,36 W/m ² K
12 cm	8 cm	2 m ² K/W	2,3 m ² K/W	0,44 W/m ² K
14 cm	6 cm	1,4 m ² K/W	1,8 m ² K/W	0,56 W/m ² K

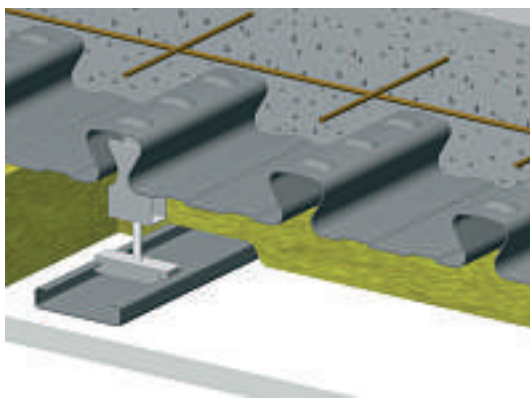

Cofrastra Décibel

If a thermal and/or acoustic insulation material is present in the plenum of the Cofrastra Décibel system, this gives the floor thermal resistance at least equal to the performance of the quilt or board used.

The thermal exchange between premises one on top of the other is therefore slightly reduced, which gives users real freedom to regulate their own heating and to manage their energy costs.

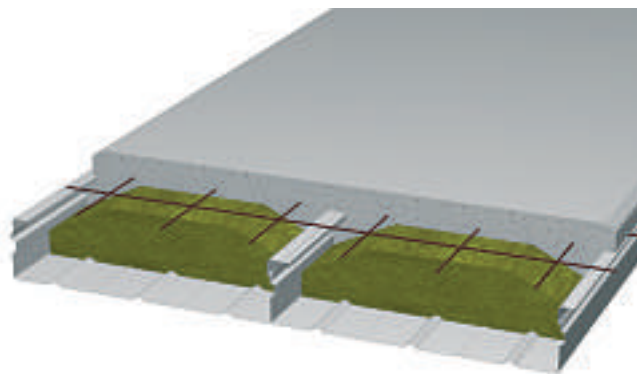

Cofradal 200

The presence of a 130 mm rock-wool panel ($R = 3.14 \text{ m}^2\text{K/m}^2$), gives the Cofradal 200 floor excellent thermal insulation.

use in seismic areas

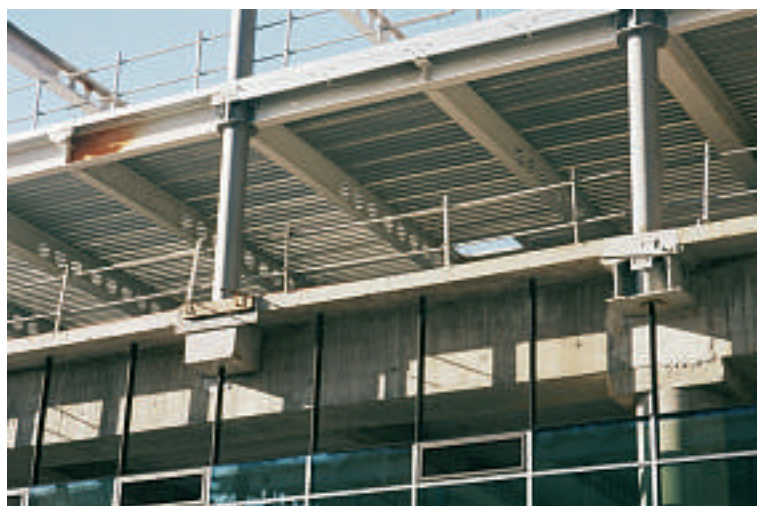

The Cofraplus, Cofrastra, and Cofradal 200 composite steel-concrete floor systems in particular, given their lightness and wide band of plasticity, offer a notable advantage in relation to seismic stress compared to an equivalent reinforced-concrete slab.

They are therefore valued and commonly used in construction projects located in seismic areas.

The contribution of composite floors to the structure's horizontal bracing (horizontal force) is also frequently used.

In this application, Cofraplus, Cofrastra, and Cofradal 200 are fixed on all supports and an appropriate number of connectors are arranged in the supports. This number is decided according to the stresses to be transferred.

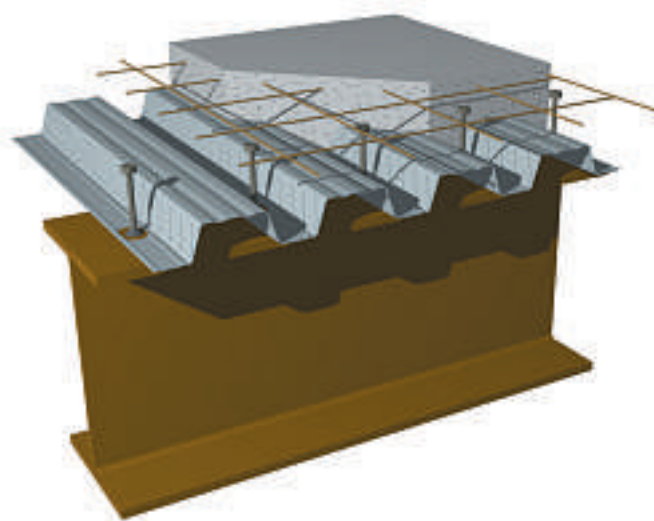

examples of design



Warehouse

Data

- **Loads:**
Imposed load: 15 kN/m²
Permanent load: 2 kN/m²
- **Fire stop:** 120 minutes

Frame

- **Beam spacing:** 4,5 m
- **Beam spans:** 10 m

Proposed solution:

The Cofrastra 70 floor was selected



Flats

Data

- **Loads:**
Imposed load: 1,5 kN/m²
Permanent load: 1,5 kN/m²
- **Fire stop:** 120 minutes

Frame

- **Beam spacing:** 5 m
- **Beam spans:** 5 m

Proposed solutions:

Two floors were selected:
- Cofrastra 40 floor: propped
- Cofradal 200 floor: unpropped



Elevated car park

Data

- **Loads:**
Imposed load: 2,5 kN/m²
Permanent load: /
- **Fire stop:** 90 minutes

Frame

- **Beam spacing (columns):** 2,5 m
- **Beam spans:** (distance between building faces) : 16 m

Proposed solution:

The Cofraplus 60 floor system was selected

EXAMPLES OF DESIGN



Offices 1

Data

- **Loads:**
Imposed load: 3,5 kN/m²
Permanent load: 1 kN/m²
- **Fire stop:** 120 minutes

Frame

- **Open-plan floors**
with no intermediate columns
- **Beam spacing:**
3 or 6 m
- **Beam spans (distance between building faces) :** 14 m

Proposed solution:

- Cofraplus 60 floor (3 m span)
- Cofradal 200 floor (6 m span)



Offices 2

Data

- **Loads:**
Imposed load: 3,5 kN/m²
Permanent load: 0,75 kN/m²
- **Fire stop:** 120 minutes

Frame

- **Beam spacing:** 3 m
- **Beam spans:** 12 m
- **Required floor space with beam springing:** maximum 700 mm including routing of networks
(i.e. electrical, water, ventilation)

Proposed solution:

The Cofraplus 60 floor was selected in combination with ACB castellated beams to enable routing of networks



School buildings

Data

- **Loads:**
Imposed load:
2,5 kN/m²
4 kN/m² (for circulation)
Permanent load: /
- **Fire stop:** 90 minutes

Frame

- **Beam spacing:** 5 m
- **Beam spans:** 10 m
- **Solives :** IFB asymmetric beams

Proposed solution:

The Cofradal 200 floor was selected



Hotels

Data

- **Loads:**
Imposed load: 2,5 kN/m²
Permanent load: 1 kN/m²
- **Fire stop:** 90 minutes

Frame

- **Beam spacing:** 3 m
- **Beam spans:** 7 m

Proposed solution:

The Cofraplus 60 floor was selected



Hospitals

Data

- **Loads:**
Imposed load:
1,5 kN/m²
2,5 kN/m² (for circulation)
3,5 kN/m² (technical areas)
Permanent load: 1 to 3 kN/m²
- **Fire stop:** 90 minutes

Frame

- **Beam spacing:** 5,5 m
- **Beam spans:** 8 m

Proposed solution:

The Cofradal 200 floor was selected



Flat roof

Data

- **Loads:**
Imposed load: 2,5 kN/m²
Permanent load: 30 kN/m²
(soil for garden roof)
- **Fire stop:** 90 minutes

Frame

- **Beam spacing:** 3 m
- **Beam spans:** 5 to 10 m

Proposed solution:

The Cofraplus 70 floor was selected

Calculating

Presentation of Arval design tools and economic comparison of the various solutions



Cofra software



Cofra is a computer-aided design program for Cofraplus and Cofrastra composite slabs, which was developed by Arval. This software can be installed on request onto your computer systems.

Arval provides Technical Assistance for its partners in order to ensure the completion and technical verification of flooring projects.

Design assumptions (regulations according to the french Technical Approval)

- Deflection criteria in the construction stage:
 $f=L/240$
- Deflection criteria in the composite stage under normal loads:
 $L \leq 3.5\text{m } f=L/350$
 $L > 3.5\text{m } f=0.5 \text{ cm}+L/700$
- Yield stress of steel reinforcement:
 $\sigma_e \geq 500 \text{ MPa}$
- Yield stress of steel deck:
The yield stress of Cofraplus, Cofrastra and Cofradal is between 320 and 350 MPa depending on the profile.
- Design values of actions:
Permanent loads: 1.35
Variable loads: 1.50

Supporting design calculations

In application of the design rules described in the addendum to the Technical Approval concerning France, or in application of the regulations pertaining to each country in relation to the project data, supporting design calculations may be established by Arval using the Cofra software.

Cofradal 200

Supporting design calculations may be established using special design software. A layout drawing software is also used for the slab layout of Cofradal 200.

Date entry

Users can enter the project source data from the structure-support drawings into the program:

- static system: number of concrete bays and deck bays,
- span of each bay,
- maximum number of props in the construction stage,
- permanent loads and live loads distributed uniformly,
- requested fire stop duration,
- sound reduction,
- construction and composite stage deflections,
- load per bay (uniform, linear loads, additional dead loads), live loads (forklifts, cars),
- usage preferences: deck type, deck thickness,
- desired slab thickness,
- if the slab is continuous, choose between a single mesh (optimises laying) and two mesh layers (optimises reinforcement consumption)

Outcome:

The Cofra software searches for the minimum slab thickness required according to the design rules described in the addendum to the Technical Approval (if in France) or those specified in the Approval pertaining to each country.

A complete description is drawn up for each solution (reinforcements, concrete, etc.). The description relating to each solution is displayed graphically on the computer screen. The user can then change parameters to reach an “optimised” solution. It is also possible to print the complete design calculations.

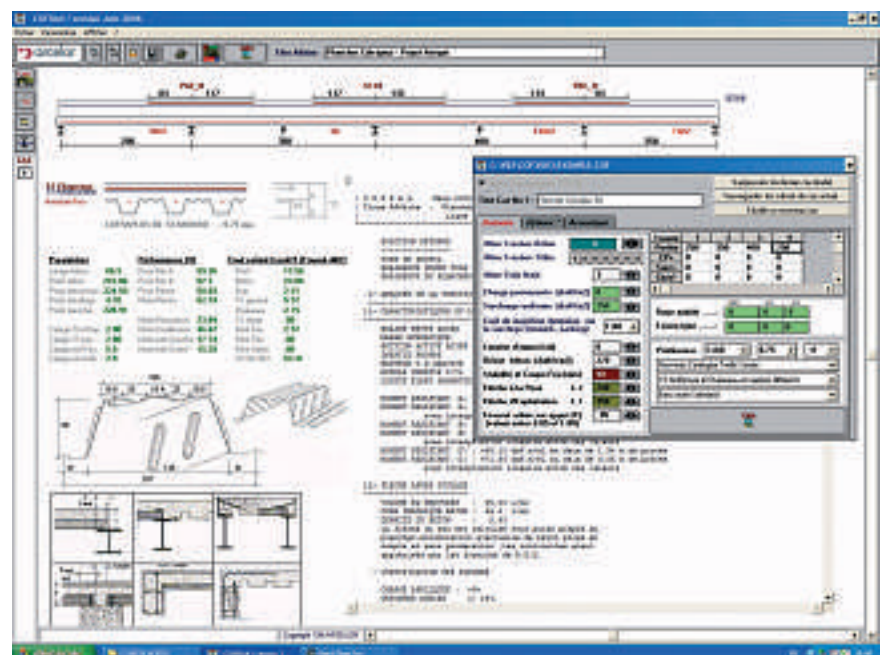

globalFloor software



globalFloor is a comparative piece of software that economically optimises flooring using beams and Arval flooring systems.

It enables frame dimensions to be selected to achieve the most economic solution taking into account the project constraints.

The components choice of the globalFloor decking, pre-dimensioning and comparison of variants to optimise economic selection, can be chosen from the pre-project stage.

globalFloor is used to specify all selection criteria in conformity with the French Technical Approvals, the Approvals of other countries, and with the Eurocodes (in the case of beams).

It is easy to use and can be configured by the user to their own requirements.

However, this predimensioning tool does not dispense with the need for a traditional technical study and its corresponding design calculations.

globalFloor takes into account:

- **requirements:** building type, imposed and permanent loads, fire stability, maximum floor-space requirement, sound insulation, and admissible deflection,
- **the assumptions to be tested with regard to the frame:** joist spans, spacing, and number, scan pitch of the possible solutions,
- **the joist and slab types:** design rules chosen, steel decks and beam types, range, with or without structure/slab connection (welded shear studs).

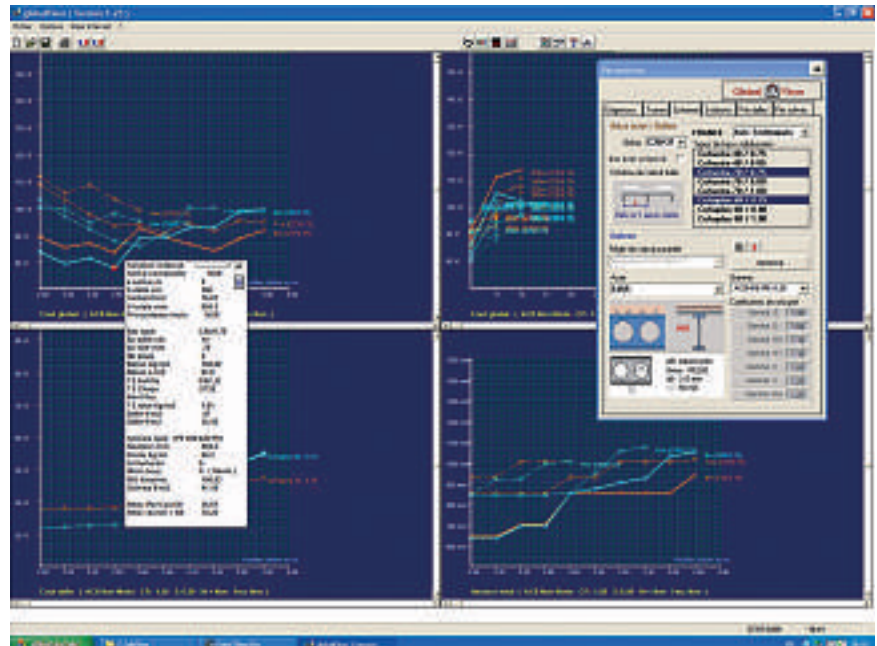

Outcome

globalFloor delivers:

- *globalFloor Software* gives a comparative summary linking up joist spans, slab spans and the overall cost of the system, thus enabling an easy choice of the right solution and at a minimum cost according to the parameters given,
- the total depth of the floor for each solution; complete description of the solution (any type of reinforcements). The description can be printed,
- quantities and estimated costs per m²,
- design calculations (link with Cofra).

The design and engineering offices also use the following dimensioning tools

- software for summary dimensioning of structures (e.g. columns and beams),
- software for castellated beam design,
- software for dimensioning of IFB asymmetric beams.

Implementing



Sport City Tower, Doha (Qatar)

ARCHITECT: Concept Architect Hadi Simaan, Florida (USA)

STRUCTURE: Arup, London (United Kingdom)

implementation sequences



Delivering of packages



Temporary storage of the packages



Deck handling

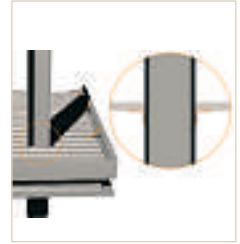
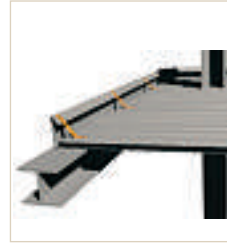

Laying the decks
Placing the edge trims

Simple, fast, practical, the implementation can be split into seven main sequences.

**Sequence 1
Temporary storage of the packages**

If the strength of the structure is sufficient, the packages can be stored near the laying area on the load-bearing structure. Do not load poured slabs still in the hardening phase

**Sequence 2
Deck handling**

Loading, walking, and working on the decks is prohibited until these are fixed and propped (the position of any props is always specified by the design and engineering office).

**Sequence 3
Placing of the edge trims**

The formwork for the edges is generally comprised of edge trims made from galvanised steel bent at the corners. They can be delivered in the dimensions required. The edge trims form the edge of the slab and are adjusted according to the line laid between the columns.

**Sequence 4
Laying of the floor decks**



Laying of the floor decks

IMPLEMENTATION SEQUENCES



Fixing and stitching of the floor deck



Any cutting



Sequence 5

Fixing and stitching of the floor deck - Any cutting

Cutting the floor deck at a skewed angle along an edge to clear a path for a column is carried out as work progresses. The cuts, which are quick and precise, are made with a nibbler or circular saw. Openings cut before concreting must be propped.



Placing of filler plugs



Adhesive tape for sealing



Box-out using steel formwork

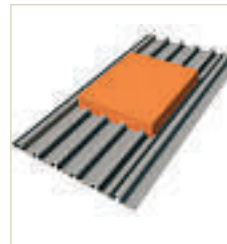

Box-out using small polystyrene block

Sequence 6

Placing of filler plugs and box-outs



Fitting of reinforcements



Pouring of concrete



Sequence 7

Fitting of reinforcements

Follow the design office's drawings and ensure that the reinforcement coverings is observed.

Pouring of concrete

The concrete must be poured from the skips onto load-bearing elements (e.g. joists or beams).

There must be no accumulation of concrete during pouring.

the 10 commandments of the layer

This chapter gives you a summary of the rules of good practice for laying Arval floors.



1. Handling and proper storage



2 Check the length of sheets



3. Pay attention to the laying direction

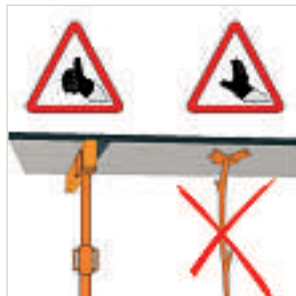

4. Use props with a continuous timber bearer



5. Prop all overhangs

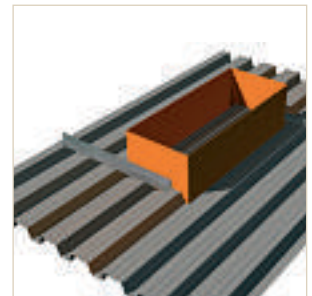

6. Comply with the drawings for floor openings

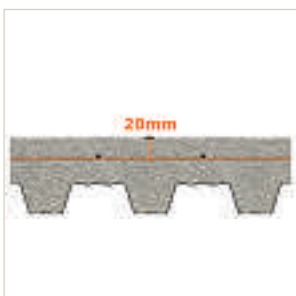

7. Comply with reinforcement coverings



8. Ensure that there is no concrete accumulation



9. Adjust the slab as work progresses

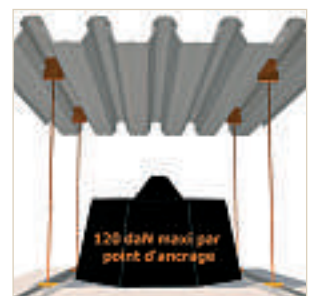

10. Comply with the rules for anchoring on the underside

handling and storage



Handling

Arval floor packaging is designed to be handled using slings (the preferred solution) or by forklift truck. It is important to adhere to the lifting points.



Deck handling

Loading, walking, and working on the decks is prohibited until these are fixed and propped (the position of any props is always specified by the design and engineering office).



Storage

The bundles must lie on bearers on a hard, clean surface. Stacked bundles (of no more than five) must be of the same length for correct positioning of the bearers. The lines of contact between the stacked sheets are sensitive to water (e.g. rain or condensation).

Poor ventilation of the packages can lead to white rust on the galvanised coat.

floor decks fixing technique

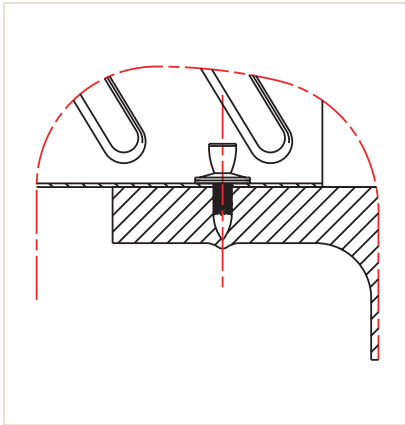

Bearing on steel frame

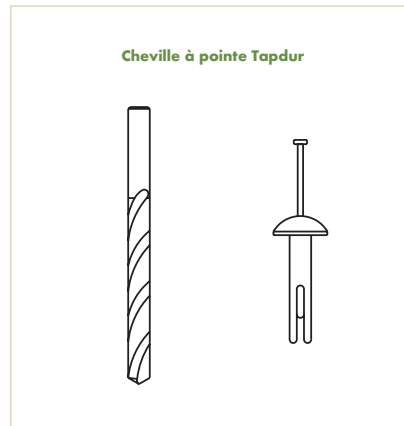

Concrete girders

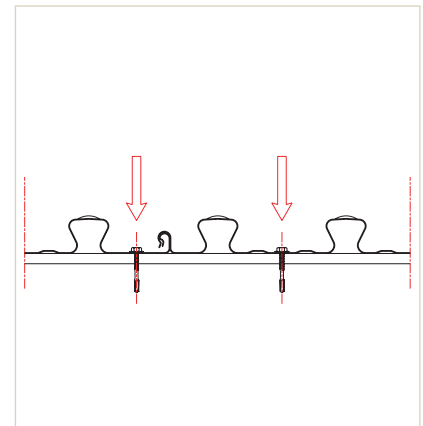

Fixings' position on Cofrastra 40

The purpose of the fixings is to ensure that the floor decks do not move under the effect of wind or from people walking over them, they join the formwork to the framework.

The fasteners heads act as markings on the support joists in order to place the top reinforcement. It is important not to walk between the supports when fixing the floor decks: the resulting deformation of these would be permanent. If the fixing to the support is not possible, the floor deck is fixed temporarily to an edge prop.

The connections between the floor decks, accessories, and the load-bearing framework, and also the fixings along the stitching lines, must be made using the following techniques:

Floor deck fixings on the load-bearing structure

The fixing type depends on the load-bearing structure. Shot-fired nails can be used to steel joists. Tapdur plugs or similar are generally used on concrete beams. Finally, in the case of a wooden framework, fixing is made with the help of coach screws or drive nails.

Fixing on end supports

Two fixings to be made for each floor deck at each end support.

FLOOR DECKS FIXING TECHNIQUE

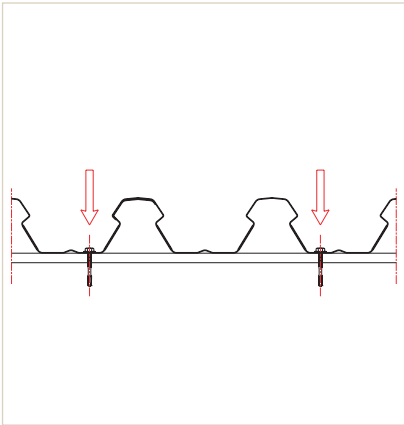

Position of fixings on Cofrastra 70

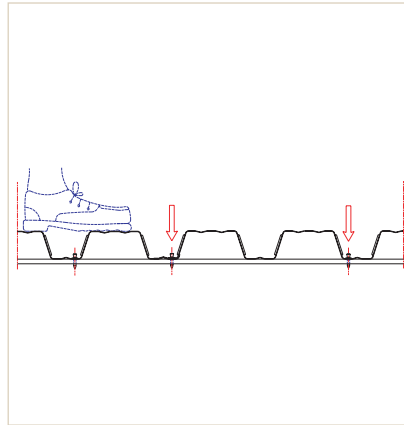

Fixing principle of Cofraplus 60

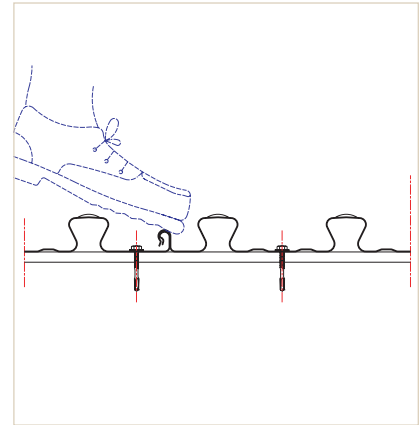

Cofrastra 40 interlocking

Fixing of side laps and accessories

Stitching of side laps and the fixing of accessories such as restraint straps are made using appropriate fastening techniques.

Blind rivets or self-tapping, self-drilling screws are two possible universal techniques.

The centres of the side lap stitching to the longitudinal overlaps between adjacent floor decks is specific to each of the Cofrastra 40 and Cofrastra 70 floor decks, and the Cofraplus and Cofrasol floor decks.

Cofrastra 40

The side lapping edge rolls of Cofrastra 40 floor decks are easily engaged under light foot or hand pressure. Clamping may be necessary if the interlocking rolls have a tendency to disengage, which can occur with particularly long panels.

Cofrastra 70

In the case of Cofrastra 70, stitching is carried out through interlocking when overlapping with the next floor deck. For large spans (more than 3 m), it is advisable to complete the fixings with two rivets or stitching screws placed at intervals of one third of the span.

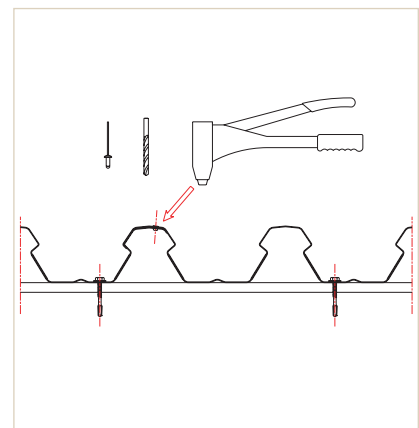

Cofrastra 70 interlocking

Open-rib floor decks: Cofraplus, Cofrasol

The stitching of the longitudinal overlaps between adjacent floor decks is achieved by installing rivets or stitching screws approximately every 100 cm in multispan and every 75 cm in single span cases.

laying of floor decks

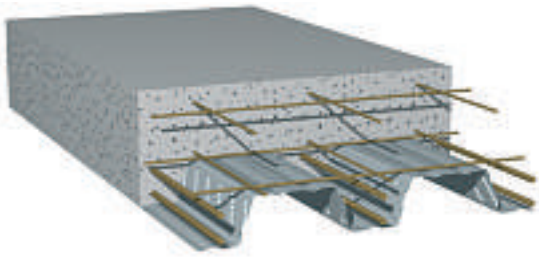

Standard section floor deck

Details of reinforcement (anti-crack mesh, flexural and/or fire-bracing reinforcement) in the standard section of the slab. A load-distribution mesh may be laid for dynamic point loads.

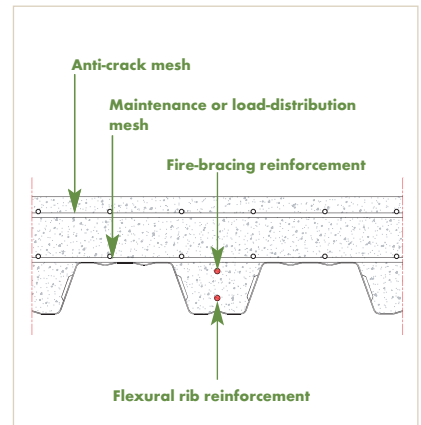

Changing floor deck direction

Where the floor deck changes direction, a Z-shaped divider of the same height as the composite floor deck section can be used to ensure that the junction is sealed.

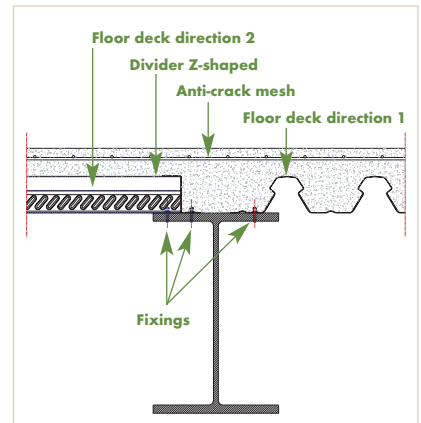
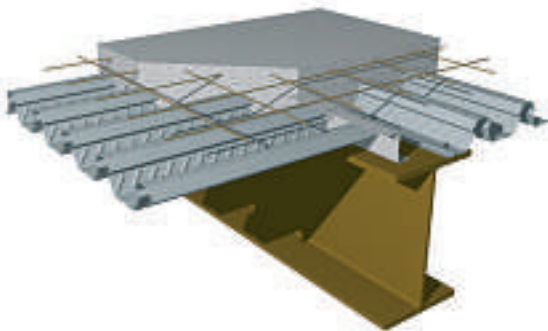

Floor deck on intermediate support

Continuous floor on a steel or concrete support.
The bearing on the support is generally greater than 80 mm.

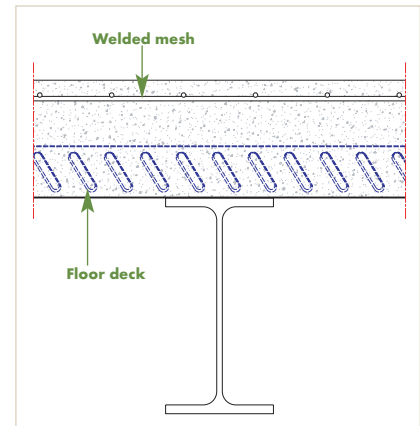
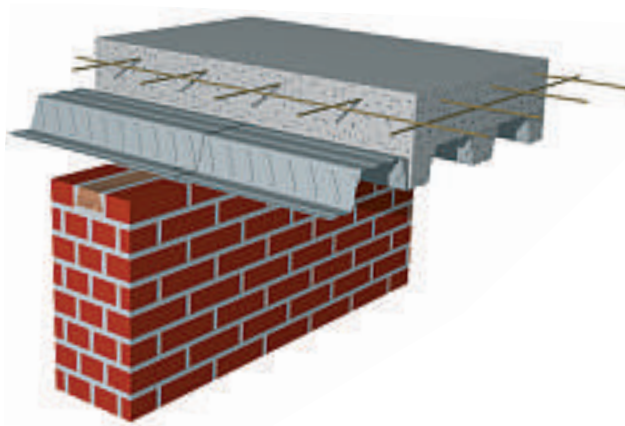
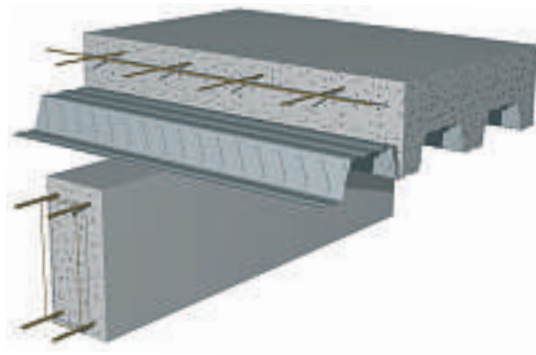
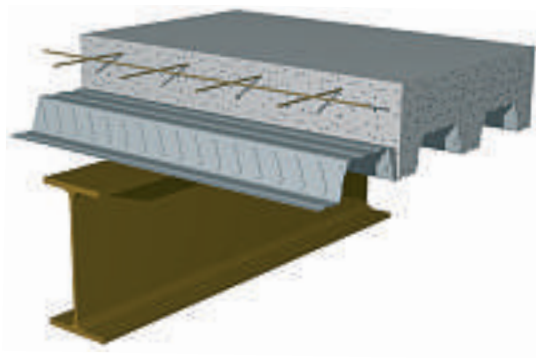

The sketch shows a single anti-crack mesh layer and top reinforcement. The top reinforcement can consist of a different layer to anti-crack mesh layer.

LAYING OF FLOOR DECKS

Deck ends

The boxing in of the edges is done by means of edge trims of a suitable size for the thickness of the floor fixed on the support. This is used to retain the wet concrete to the correct level at the decking perimeters.

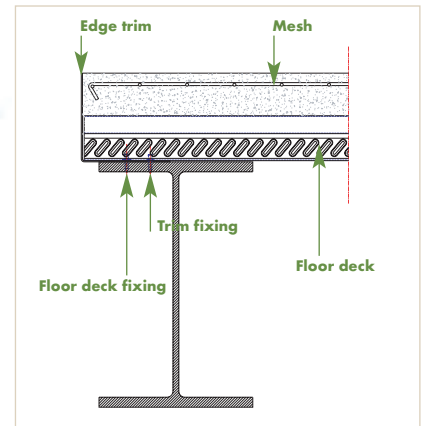
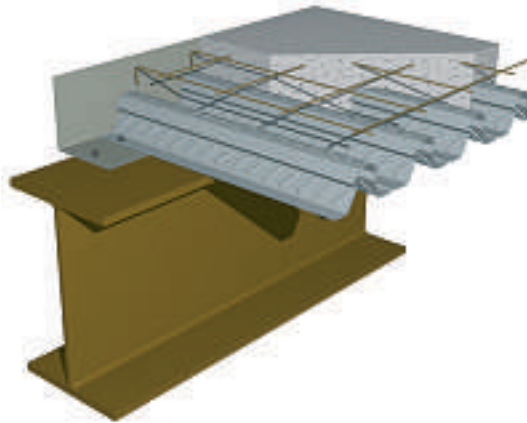

Trim fixed on steel support

The fitting of restraint straps, which ensure that the edge trim is held in place, is recommended for of 15 cm or more.

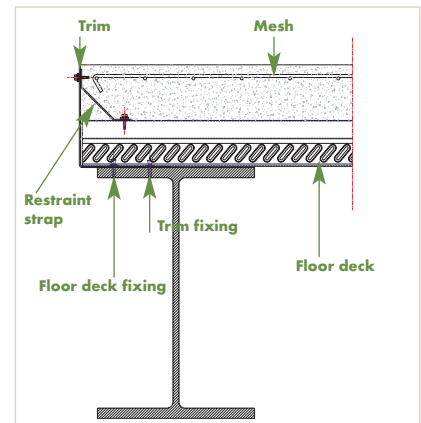
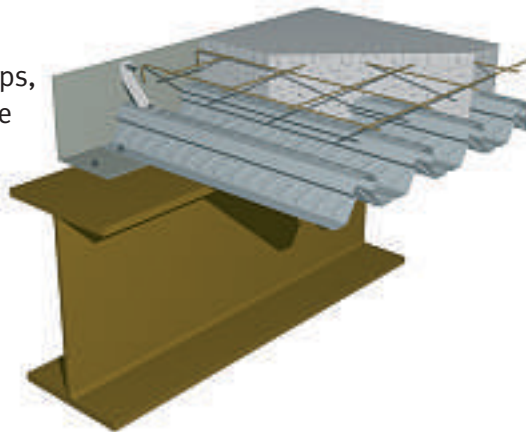

Trim fixed on steel support and restraint strap

The edge trim can be used for designing reinforcement at floor decks ends.

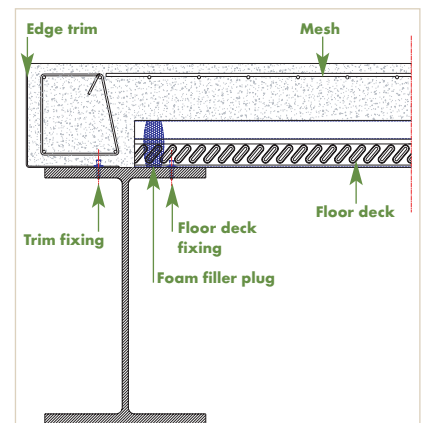
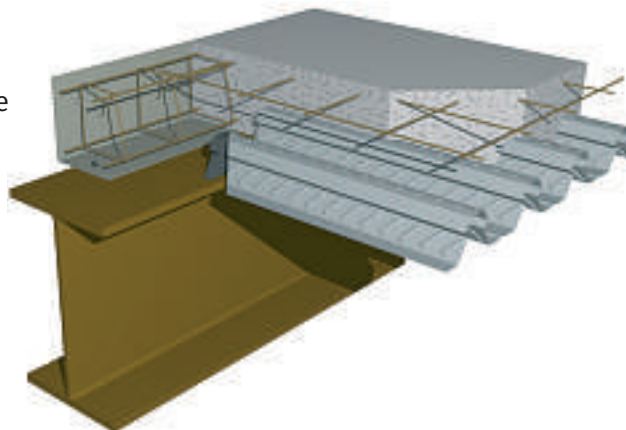

End support with embedded reinforcement on steel beam

Rebate laying on reinforced concrete beams

In the case of concrete supports, sometimes there is not enough of a base to provide the 50 mm of bearing needed, in which case it is necessary to create supports by incorporating or fixing angle brackets into the concrete beam.

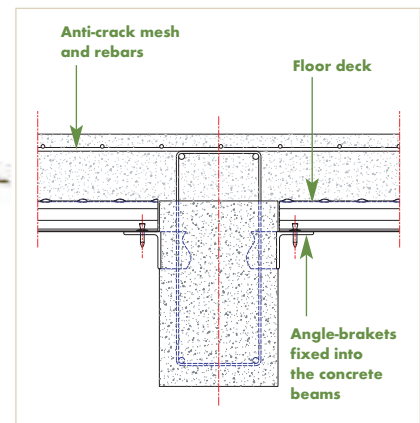
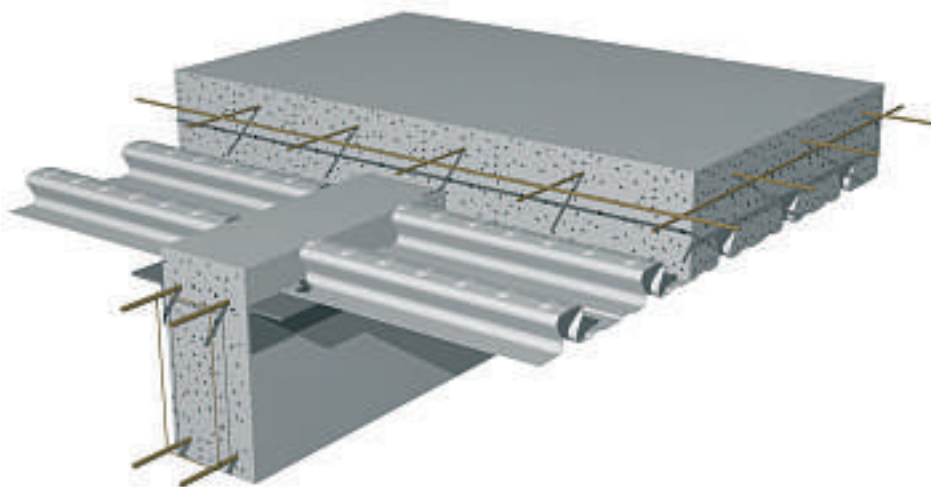

LAYING OF FLOOR DECKS

Position of main beam

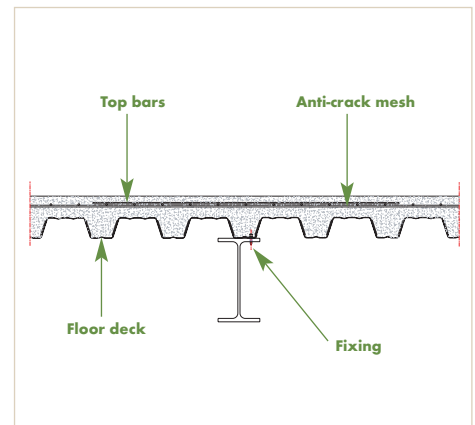
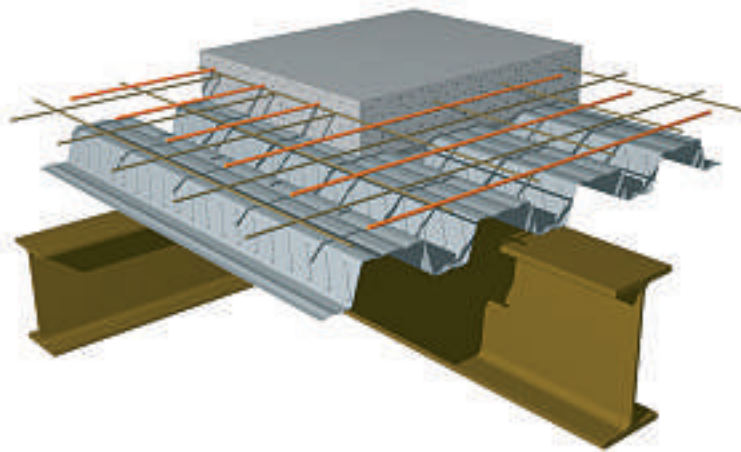

Beam parallel to the ribs

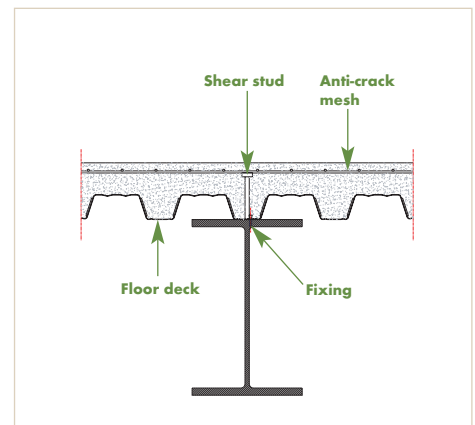
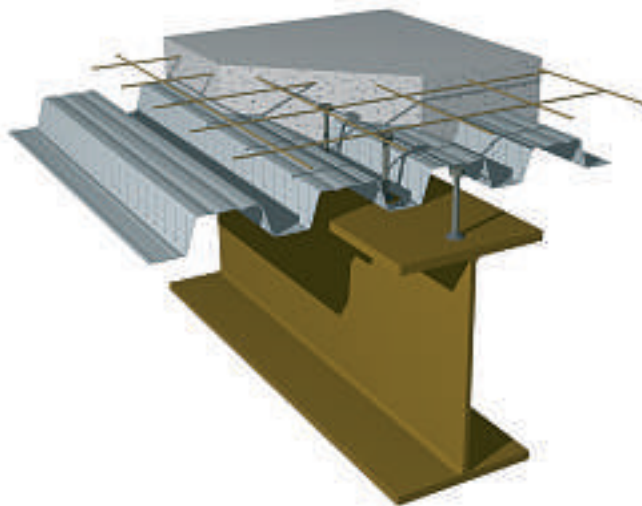

Composite beam

Where the main beam is parallel with the deck ribs, the deck layout plan must provide for a corrugation trough to rest on and possibly be fixed to the main beam.

If the main beam is to be designed as part of the composite construction, the bottom rib must be well centred on the top flange of the beam. Transversal top bars must also be fitted onto the main beam.

LAYING OF FLOOR DECKS

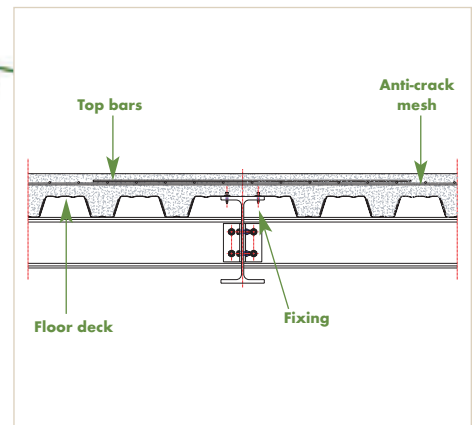
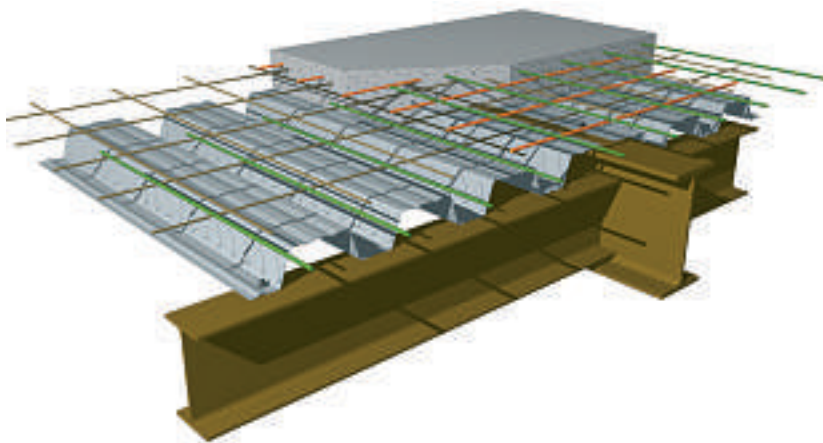

Slab on main beam

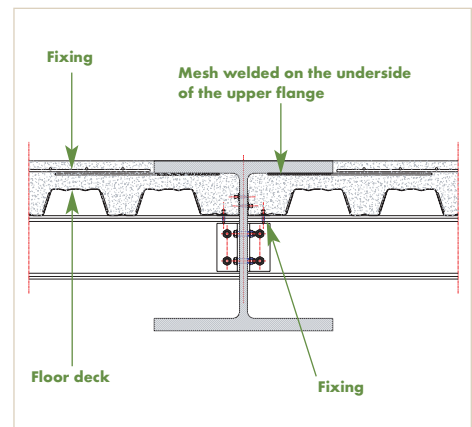
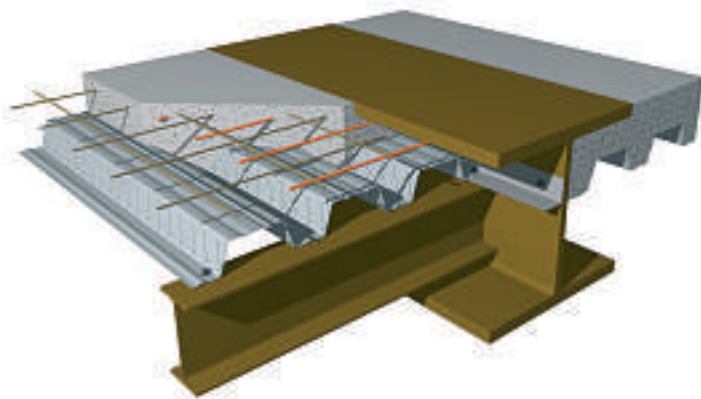

Slab on the level of the main beam

If the main beam is not at the same level as the deck support joists, construction layouts may be proposed.

LAYING OF FLOOR DECKS

Placing props

60 mm wide props must be stabilised on the ground.

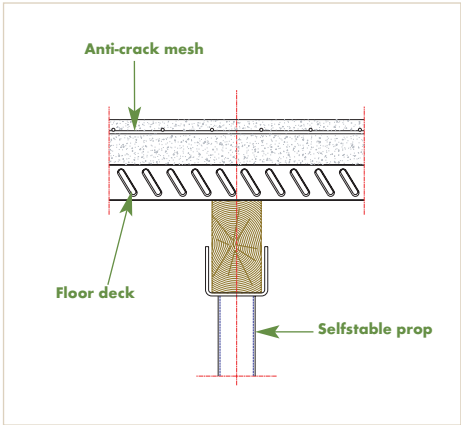
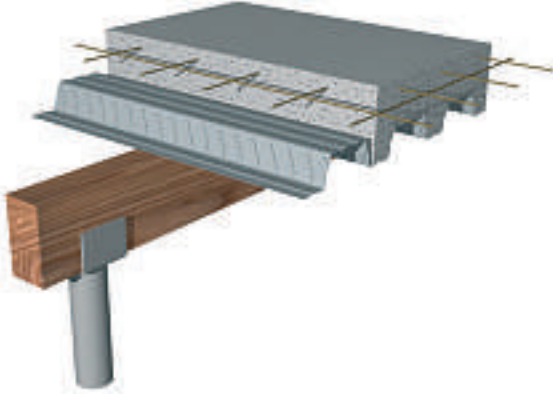

Standard section prop

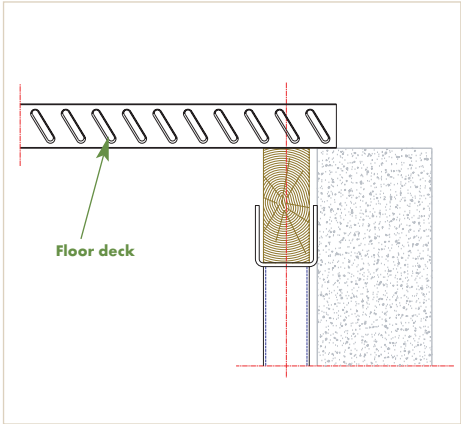
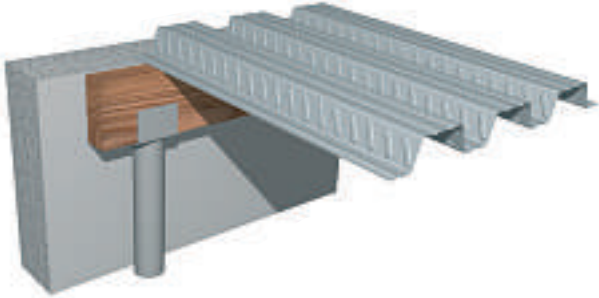

Edge prop

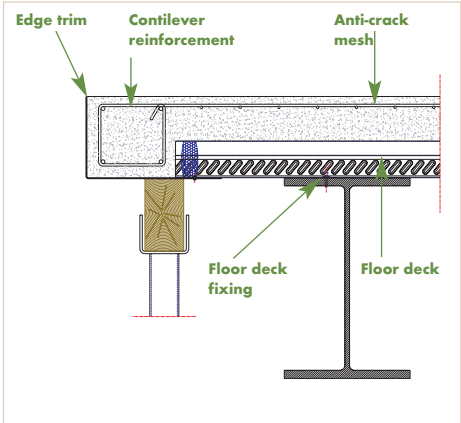
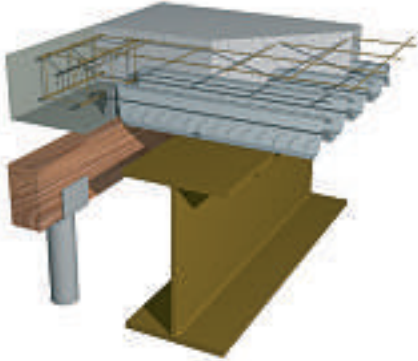

Prop under edge trim

Bearing on brickwork

In this case, where a support is provided using a recess in the brickwork, it is necessary to place a prop against the wall in the casting phase.

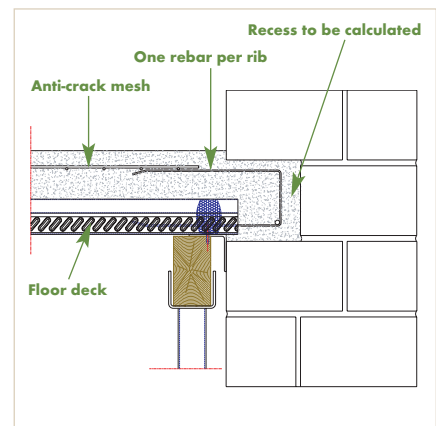

Floor bearing on brickwork-wall

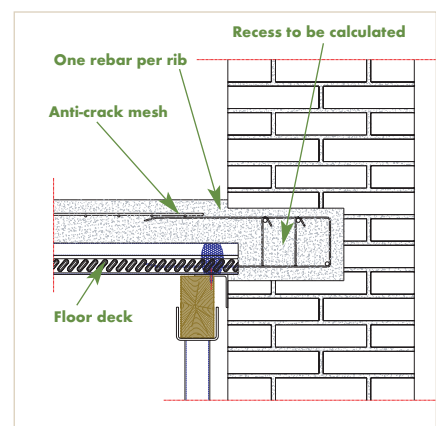
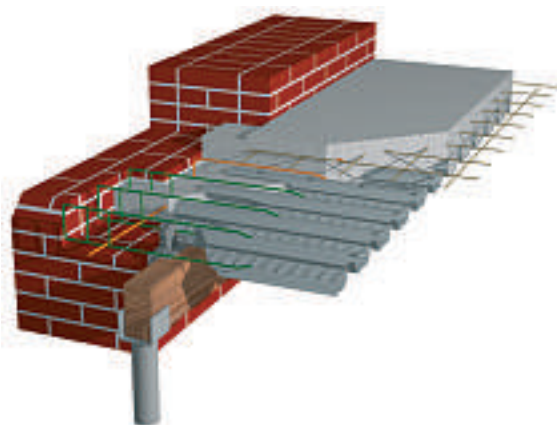

Floor bearing on brickwork-wall

LAYING OF THE DECKS

Overhang

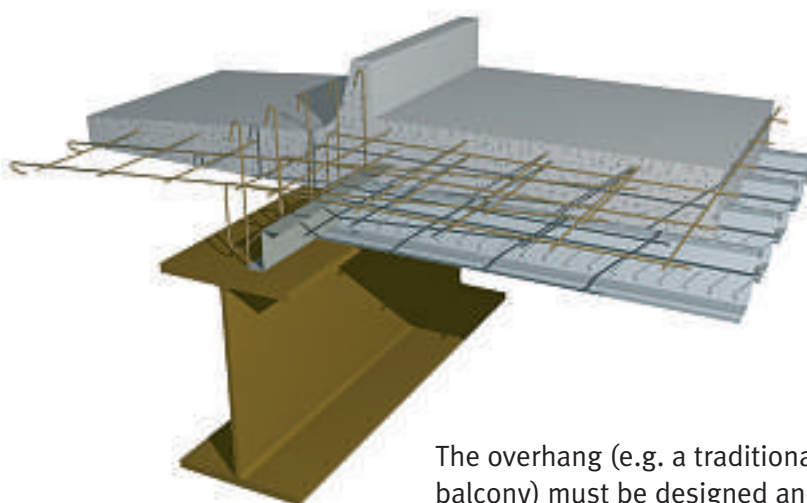

The overhang (e.g. a traditional balcony) must be designed and constructed as a reinforced-concrete slab.

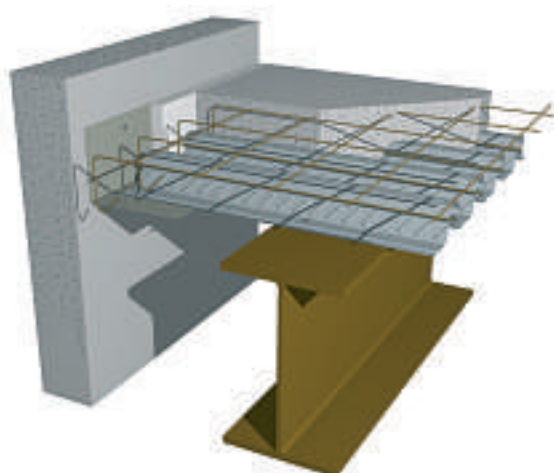
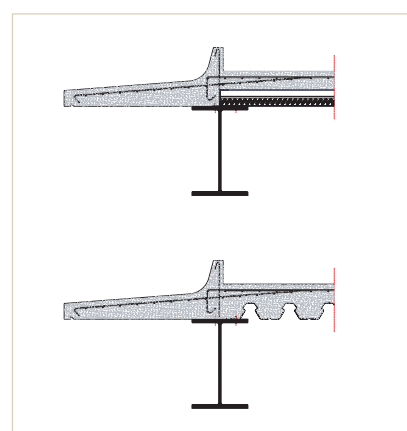

If the angle bracket on the wall has not been designed as a support, the part of the floor against the wall must be considered as an overhang.

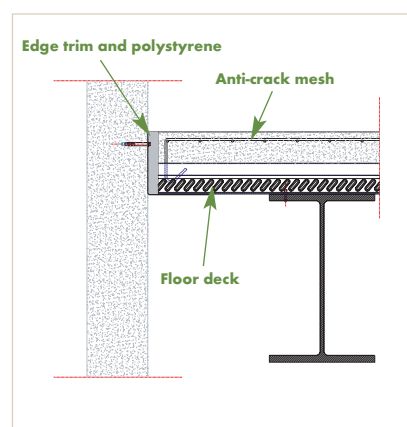

Trimmers and floor openings



For small openings in the central area, a timber shutter or a polystyrene block is temporarily placed before concreting.

Once the concrete has hardened, the sheet is cut away. Two corner brackets are used to transmit the force of the side load-bearing strips.

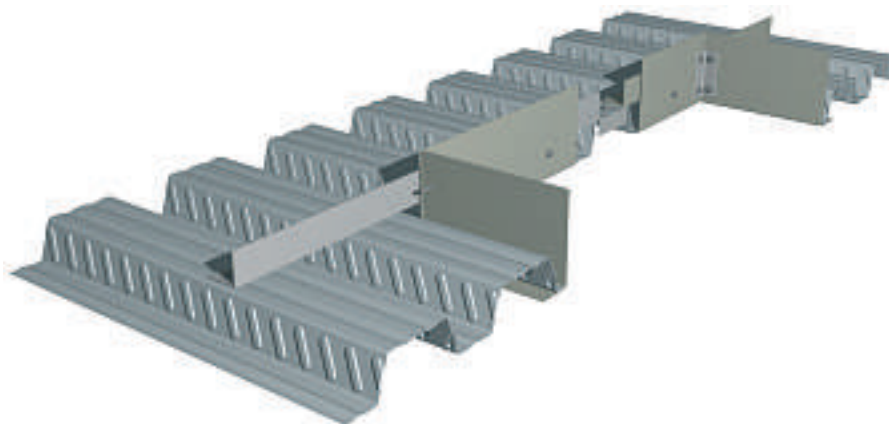
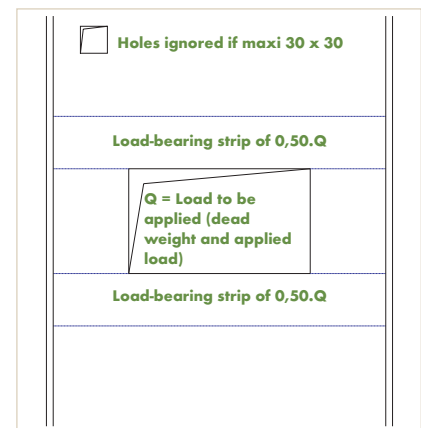

If the opening exceeds 50 x 50 cm, a cavity system made up of crosswise, longitudinal corner plates, and support brackets can be used.

This system integrated into the slab serves as a trimmer and reinforces the slab around the opening.

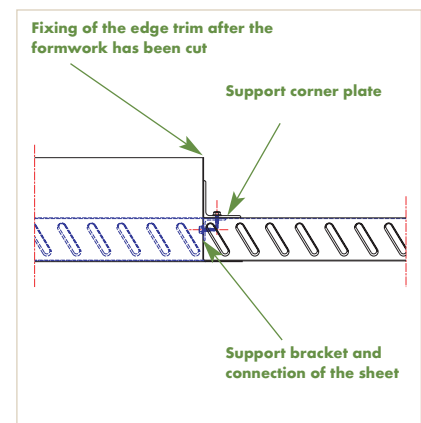

LAYING OF THE DECKS

Composite beam –connectors

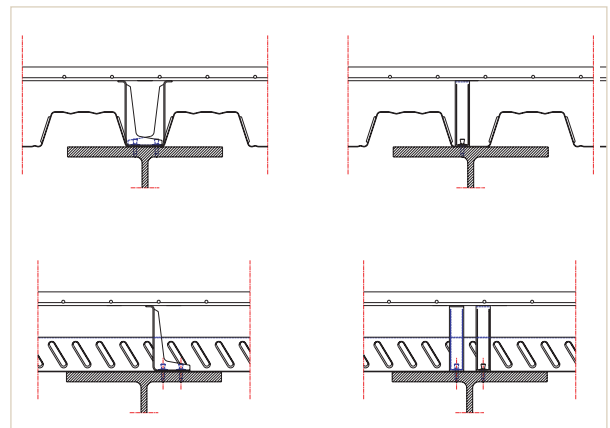
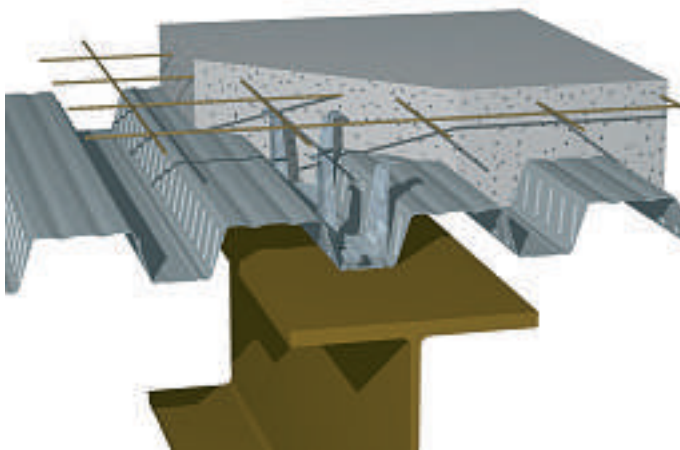

Floor decks can be perpendicular or parallel to a composite beam.
Example of fitting conditions for Hilti angle connectors

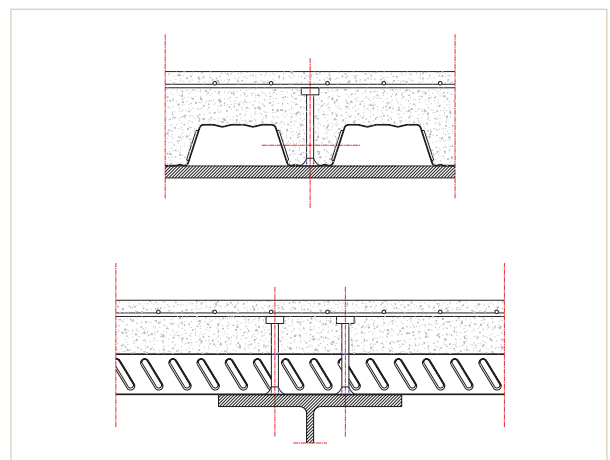
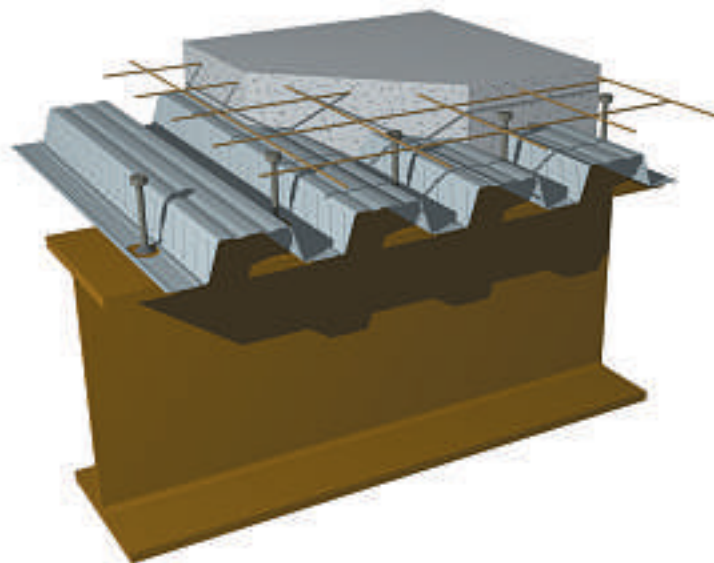

Example of fitting conditions for shear studs.

laying of Cofradal 200

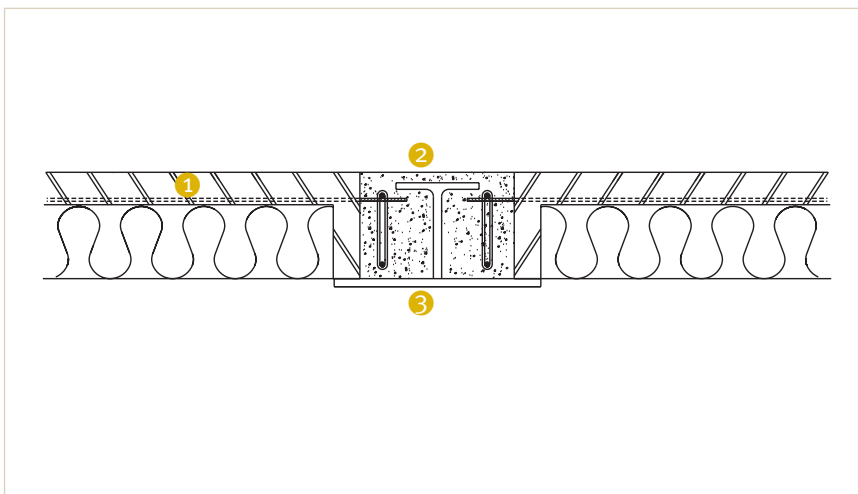

IFB steel beam connection

- 1 Cofradal 200
- 2 Reinforcement
- 3 Bearing beam

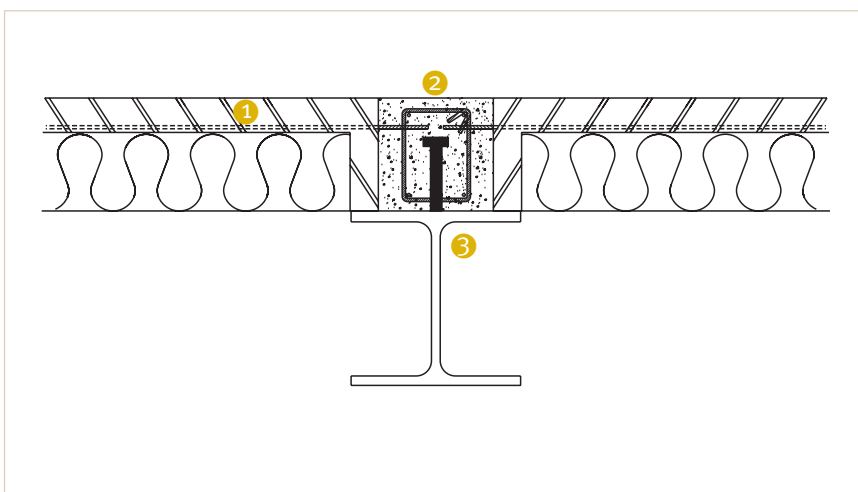

Composite beam connection

- 1 Cofradal 200
- 2 Reinforcement
- 3 Bearing beam

LAYING OF COFRADAL 200

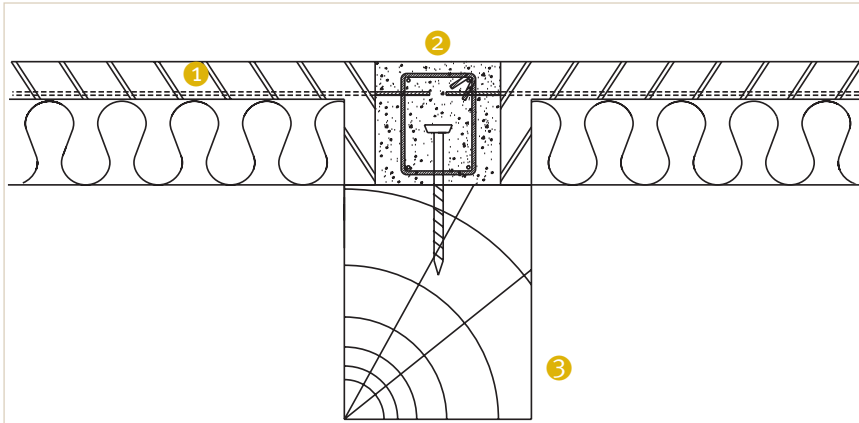

Wooden joist connection

- 1 Cofradal 200
- 2 Reinforcement
- 3 Wood joist

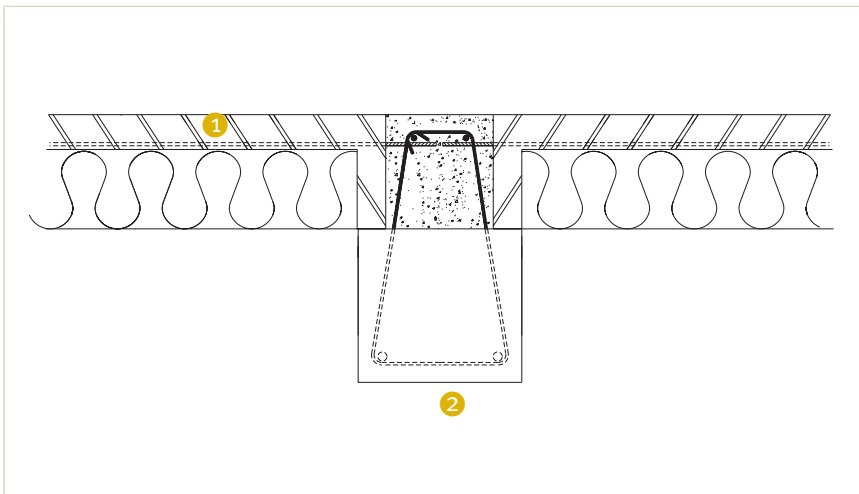

Intermediate support – Reinforced concrete beam

- 1 Cofradal 200
- 2 Reinforced concrete beam

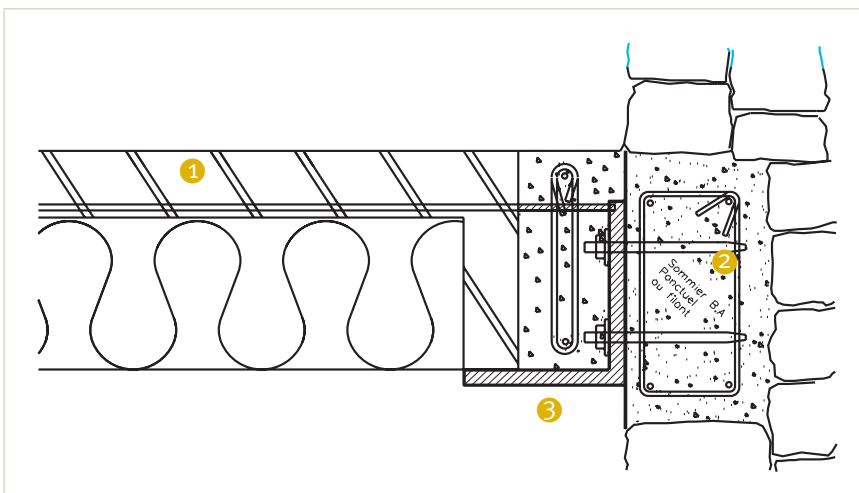

Support on metal corner bracket - renovation

- 1 Cofradal 200
- 2 Padstones or continuous reinforced concrete beam
- 3 Continuous angle bearing

LAYING OF COFRADAL 200

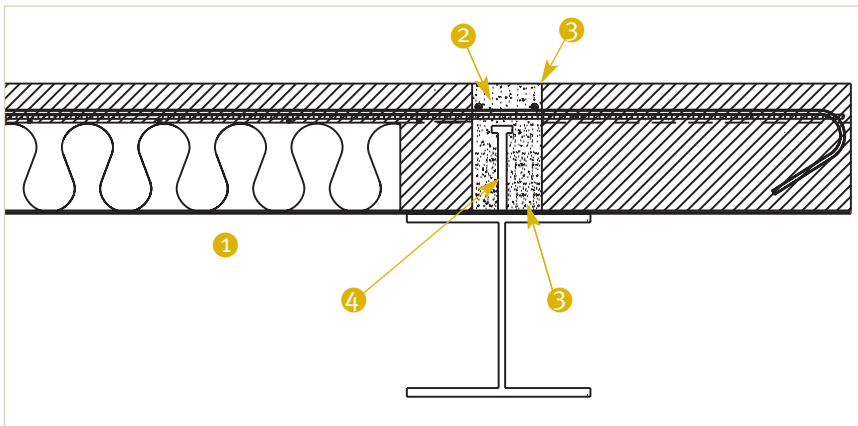

Overhang - steel structure

- ① Cofradal 200
- ② Notches on each element
- ③ Continuous rebar f 8 placed on site
- ④ Shear stud

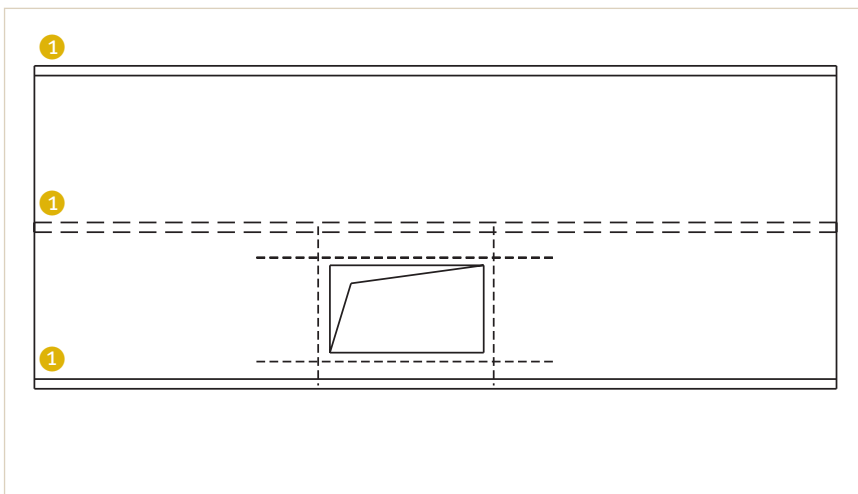

Opening with dimensions less than 400 x 600 mm

- ① Rib

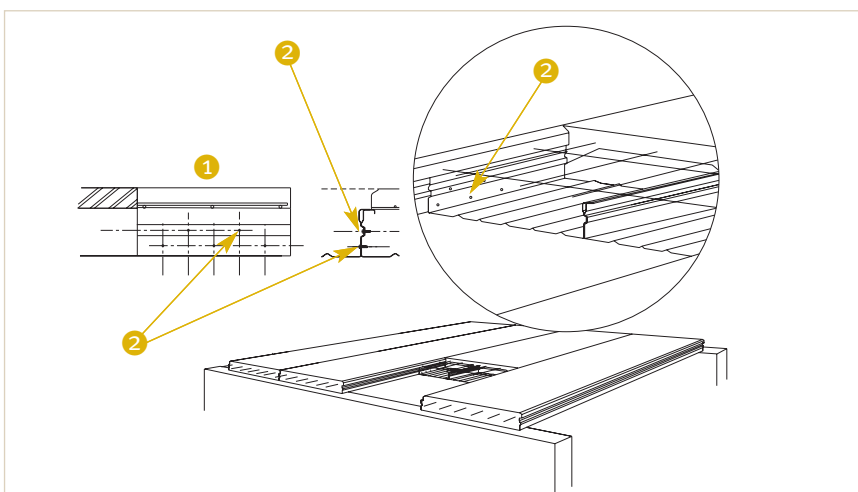

Opening less than 1200 mm wide

- ① Recess zone
- ② Self drilling screws 6,3 x 25

LAYING OF COFRADAL 200

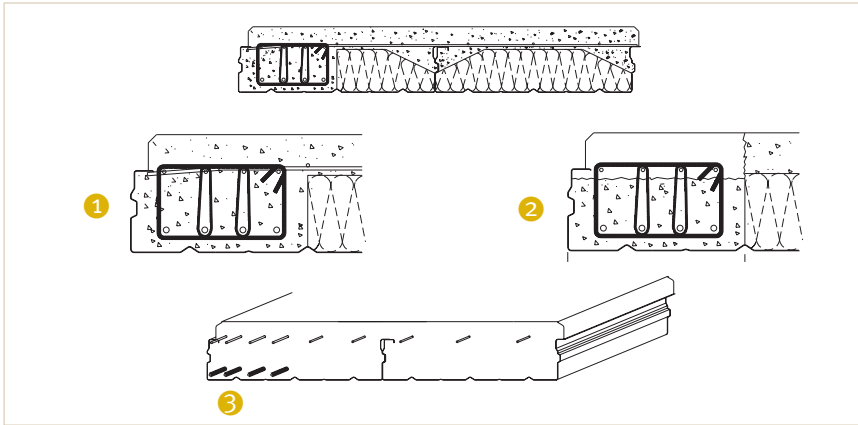

Integrated embedded strips

- 1 Level keying of the embedded strips
- 2 Box-out cavities 40x30x8ht
- 3 Embedded strips

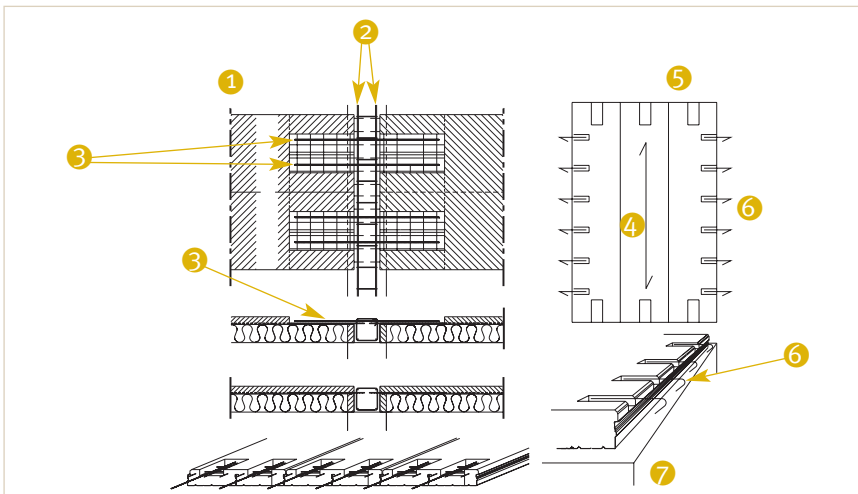

Earthquake-resistance measures

- 1 Connection on the load-bearing support
- 2 Beam or reinforcement
- 3 Rebar f 6 in each notch
- 4 Cofradal 200
- 5 Load-bearing support
- 6 Edge
- 7 Edge connection

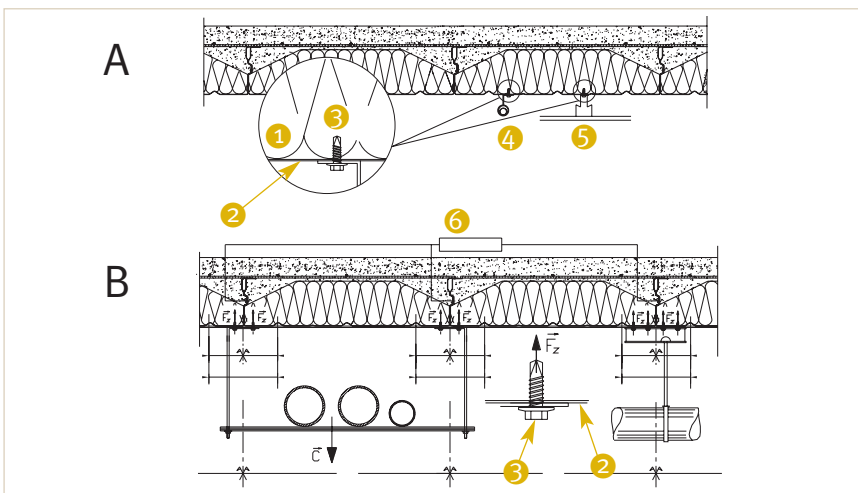

Fixing on the underside of Cofradal 200 floor elements

A/ Suspended ceilings, electrical duct, light fitting

- 1 Rock wool
- 2 Tray 10/10°
- 3 Screw type SFS SD2-T16-6,3 x 19 (or similar)
- 4 Electrical cable
- 5 Suspended ceiling type BA13

B/ Suspended networks, hydraulic, acclimatisation

- 6 Tray valleys

Arval Arval Arval Arval Arval Arval

Austria

ARVAL ARCELORMITTAL CONSTRUCTION
AUSTRIA GmbH
Lothringerstraße 2
A-4501 Neuhofen an der Krems
Tel. +43 72 27 52 25

Belgium

ARVAL ARCELORMITTAL CONSTRUCTION
BELGIUM
Voogdijstraat 31
B-3500 Hasselt
Tel +32 11/286/770

Bosnia

ArcelorMittal Construction BiH
Pijačna 6
71000 Sarajevo
Bosna i Hercegovina
Tel.+387 (0) 33 63 50 22 Fax.+387 (0)
33 63 50 23

Croatia

ArcelorMittal Construction Croatia d.o.o.
Bani bb
10000 Zagreb
Hrvatska
T +385 1 6607 532

Czech Republic

ARVAL ARCELORMITTAL CONSTRUCTION
CZ s.r.o.
Prátelstvi 681
CZ 104 00 Praha 10
Tel. +420 272 072 020

Denmark

ARVAL HAIRONVILLE DANMARK
Tæbyvej 17
DK -2610 Rodovre
Tel. +45 36 41 30 22

France

ARVAL
16 route de la Forge
F-55000 Haironville
Tel. +33 3 29 79 85 85

Germany

ARVAL ARCELORMITTAL CONSTRUCTION
DEUTSCHLAND
Münchener Straße 2
D-06796 Brehna
Tel. +49 3 49 54 455 20

Greece

ARVAL ARCELORMITTAL CONSTRUCTION
HELLAS
2nd Industrial Area
P.O. Box 1137
GR-38001 Volos
Tel. +30 24250 61 000

Hungary

ARVAL ARCELORMITTAL CONSTRUCTION
HUNGARY Kft
Váci út 184
HU-1138 Budapest
Magyarország
Tel. +36 1 350 2876

Italy

ARVAL Agenzia Generale per l'Italia
Via Vincenzo Bellini ,13
20124 MILANO
Tel. +39 02 79 95 68

Latvia

ARVAL ARCELORMITTAL CONSTRUCTION
LATVIA SIA
Cierkurkalna 1 linija 84-208
RIGA LV 1026
LATVIA
Tel.+371 674 36331

Lithuania

ARVAL ARCELORMITTAL CONSTRUCTION
BALTIC
Kirtimu g. 11
LT-02244 Vilnius
Tel. +370 5 2644 220

Netherlands

ARVAL ARCELORMITTAL CONSTRUCTION
NEDERLAND
Biezenwei 2
NL-4004 KD Tiel
Tel. +31 3 44 63 17 46

Norway

ARVAL ARCELORMITTAL CONSTRUCTION
NORGE AS
Dyrskueveien 16
N-2040 KLOFTA
Tel. +47 63 94 72 72

Poland

ARVAL ARCELORMITTAL CONSTRUCTION
POLSKA
Sp. z o.o.
Konopnica 120
PL- 96 200 Rawa Mazowiecka
Tel. +48 22 213 38 00

Portugal

ARVAL ArcelorMittal Construção Portugal,
SA
Estrada Nacional 3 (Km 17,5)
PT-Apartado 14 2071 -909 Cartaxo
Tel. +351 263 400 070

Romania

ARVAL ARCELORMITTAL CONSTRUCTION
ROMANIA
B-dul Biruintei , nr.136
077145 Pantelimon, judetul Ilfov
Tel. +40 21 312 45 17

Slovakia

ARVAL ARCELORMITTAL CONSTRUCTION
SLOVAKIA s.r.o
Roznavska 24
SK-83104 Bratislava
Tel. +421 2 44 63 40 44

South Africa

ARVAL ARCELORMITTAL CONSTRUCTION
SOUTH AFRICA
The Place-1 Sandton Drive
Sandhurst-Sandton 2196
Gauteng-South Africa
Tel +27 11 722 8621

Spain

ARVAL ARCELORMITTAL CONSTRUCCIÓN
ESPAÑA S.L.
Carretera Guipuzcoa no 3 Km 7,5
SP-31195 Berrioplano (Navarra)
Tel. +34 948 138 668

Sweden

ARVAL ARCELORMITTAL CONSTRUCTION
SVERIGE AB
Västanvindsgatan 13
SE-652 21 Karlstad
Tel. +46 54 68 83 00

Switzerland

ARVAL ARCELORMITTAL CONSTRUCTION
SUISSE SA
Postfach -Studacherstrasse 7b
CH-5416 Kirchdorf
Tel. +41 56 296 10 10
International :
info@arcelormittal-construction.ch

United Arab Emirates

Studacherstrasse 7b
CH-5416 Kirchdorf
Tel. +41 56 296 10 10

United Kingdom

ARVAL ARCELORMITTAL CONSTRUCTION
UK LTD
Abbotsfield Road
Abbotsfield Industrial Park
UK St Helens, Merseyside WA9 4HU
Tel. +44 17 44 81 81 81

Russia

ARVAL COLORPROFIL ARCELORMITTAL
CONSTRUCTION MOSCOW
Business Center "Ordynka"
Bld. 4 2nd floor, of1
RU-119017 Moscow
Tel. +7 495 514 08 96

Guadeloupe

ARVAL PROFILAGE DE LA GUADELOUPE
51 rue Henri Becquerel
ZI de Jarry
F-97122 Baie Mahault
Tel. +590 26 82 03

Martinique

ARVAL PROFILAGE DE LA MARTINIQUE
ZIP de la Pointe des Grives
F-97200 Fort de France
Tel. +596 60 60 00

Saint Martin

ARVAL PROFILAGE SAINT MARTIN
ZAC Lot 3 et 4 La Savane Activité
F-97150 Saint Martin
Tel. +590 52 98 04

Dominican Republic

ARVAL PROFILAGE DOMINICANA S.A.
Prolongacion Av. Charles de Gaulle, 131
Dominican Republic-Santo Domingo
Tel. +1 (809) 483 2790

Guyane

ARVAL HAIRONVILLE GUYANE
ZI de Degrad des Cannes
BP 418
F-97300-REMI-REMONT-JOLY
Tel. +594 25 52 21

Réunion

ARVAL PROFILAGE DE LA REUNION
ZI N°2 -44 rue Paul Verlaine
BP 802
F-97825-Le Port CEDEX
Tel. +262 42 42 42

Mauritius

ARVAL PROFILAGE DE L'OCEAN INDIEN
Route de la Filature
Mauritius-Riche Terre
Tel. +230 248 17 05

Brazil

ARVAL PERFILOR S.A. CONSTRUCOES
IND E COM
Rua dos Pinheiros, 498 cj 91
Brazil 05422 000-Sao Paulo SP
Tel. +55 11 3065 3400

For other countries :

Contact :
ARVAL ARCELORMITTAL CONSTRUCTION
FRANCE
Export Department
16 route de la Forge
F-55000 Haironville
Tel. +33 3 29 79 85 85

Design: Arval

Realisation: Cedam

Graphic design: graficdesign@free.fr

Printing: Soregraph, February 2009

Photographical credits:

Arcelor Construction **except for p. 5:** MIDMAC-Sixco; **p. 20:** M. Denancé; **p. 21:** K. Khalfi (top); **p. 27:** DR; **p. 31:** E. Cervo (right, below); **p. 34:** DR (below); **p. 44:** DR; **p. 71:** MIDMAC-Sixco



Arval

Web sites

www.arval-construction.com
www.arcelor-construction.com

This brochure is not a contractual document. The technical information provided in all the documents is given for guidance only and cannot give rise to any liability on our part. Should the documents be in contradiction with more recent official documents, the latter shall prevail.

Third edition - February 2009